

Grid-Hybrid Inverter SPM 8000-10000TL-HU



User Manual



Datalogger Manual



044.SK0016700

Version: 1.0

Shenzhen Growatt New Energy Co., Ltd
4-13/F, Building A, Sino-German (Europe) Industrial Park,
Hangcheng Ave, Bao'an District, Shenzhen, China

T +86 0755 2747 1942
E service@ginverter.com
W www.ginverter.com

GR-UM-142-A-00

Table Of Contents

1 Information on this Manual	1
1.1 Overview	1
1.2 Intended Audience	1
1.3 Safety Instructions	1
2 Production Introduction	3
2.1 Product Overview	3
2.2 Function Port Definition	4
2.3 Product Size	5
2.4 Product Features	5
2.5 Basic System Architecture	6
3 Installation	7
3.1 Parts List	7
3.2 Mounting Instructions	7
3.3 Battery Connection	9
3.4 Grid Connection and Backup Load Connection	10
3.5 PV Connection	11
3.6 Meter or CT Connection.....	12
3.7 Earth Connection	13
3.8 Dip Switch Status	13
3.9 Fan Replacement.....	13
3.10 Wiring System for Inverter.....	14
3.11 Single Phase 230Vac Parallel Connection	16
3.12 3Pcs Parallel Connection for 230/400Vac Three Phase	18
3.13 6Pcs Parallel Connection for 230/400Vac Three Phase	20
4 Operations on the ShineTools App	22
4.1 Overview	22
4.2 APP Download	22
4.3 Login	22
4.4 Direct WiFi/Bluetooth Commissioning Tool	23
4.5 Commissioning of SPM 8000-10000TL-HU	24
4.6 Parameter Setting (Specific to the App display setting items)	25
5 Operations on The ShinePhone APP	26
5.1 Overview	26
5.2 APP Download	26
5.3 APP Introduction	27
6 Operation	35
6.1 Power ON/OFF	35
6.2 Operation and Display Panel	35

7 Main Screen	36
7.1 Touch Screen Operation Flow Chart	36
7.2 Main Screen	37
7.3 Setting Menu	40
7.4 Basic Settings	41
7.5 Battery Settings	41
7.6 Operating Modes	43
7.7 Grid Settings	47
7.8 Generator Settings	49
7.9 Advanced Functions	50
7.10 Device Info.	51
8 Error Information and Processing	52
9 Data Sheet	56
10 Appendix I	58
11 Appendix II	58
12 Appendix III	59
13 Appendix IV	59
14 Appendix V	59

1 Information on this Manual

1.1 Overview

This manual is intended to introduce the SPM 8000-10000TL-HU Inverters manufactured by Shenzhen Growatt New Energy Co.,Ltd. (hereinafter referred to as Growatt) in terms of the installation, operation, commissioning, maintenance and troubleshooting. Please read this manual carefully before using the product, and keep it in a place that is easily accessible to installation, operation and maintenance personnel. The content is continually reviewed and amended as necessary. Growatt reserves the right to make changes to the material at any time and without notice.

1.2 Intended Audience



Only qualified electrical technicians are allowed to install SPM 8000-10000TL-HU Inverters. Reading through this manual and observing all the precautions, qualified electrical technicians will be able to properly install, troubleshoot and configure the SPM 8000-10000TL-HU Inverters. If any questions arise during installation, you can visit www.growatt.com and leave a message.

1.3 Safety Instructions

1. Please read this manual carefully before installation. Damages caused by failure to follow the instructions in the manual are beyond the warranty scope.
2. Only qualified and trained electrical technicians are allowed to perform operations on the Storage Inverter.
3. During installation, please do not touch other parts inside the equipment except wiring terminals.
4. Ensure that all electrical connections comply with local electrical standards.
5. For maintenance, please contact designated local installation and maintenance personnel.
6. Before operating the inverter in the on-grid mode, ensure that you have obtained any permission needed from the local electricity grid network operator.



- a. Electrical installation, repairs and conversions may only be carried out by electrically qualified persons.
- b. DO NOT connect the grid to the Load Output Breaker.
- c. DO NOT reverse the polarity of batteries. Damage WILL occur.
- d. The components in the inverter are live. Touching live components can result in serious injury or death.
- e. Non professional, please do not open the inverter.
- f. Beware of high PV voltage. Please turn-off the DC switch of PV Panel output before and during the installation to avoid electric shock.
- g. Beware of high grid voltage. Please turn-off the AC switch at the grid connection before and during the installation to avoid electric shock.
- h. Beware of large current of the battery output. Please turn-off the battery module before and during the installation to avoid electric shock.

 WARNING	<ul style="list-style-type: none"> a. Make all electrical connections (e.g. conductor termination, fuses, PE, connection, etc.) in accordance with prevailing regulations. When working with the inverter powered on, adhere to all prevailing safety regulations to minimize risk of accidents. b. Systems with inverters typically require additional control (e.g. switches, disconnects) or protective devices (e.g. fusing circuit breakers) depending upon the prevailing safety rules. c. ALL terminals/breakers including battery, MPPT, and AC breaker inputs should only have one conductor connecting to them. d. Anytime the inverter has been disconnected from the power net work,use extreme caution as some components can retain charge sufficient to create a shock hazard; to minimize occurrence of such conditions,comply with all corresponding safety symbols and markings present on the unit and in this manual. e. Ensure all covers and doors are closed and secure during operation. All operations regarding transport, installation and start-up, including maintenance must be operated by qualified, trained personnel and in compliance with all prevailing codes and regulations. f. Although designed to meet all safety requirements, some parts and surfaces of Inverter are still hot during operation. To reduce the risk of injury, do not touch the heat sink at the back of the PV-Inverter or nearby surfaces while Inverter is operating.
 NOTICE	<ul style="list-style-type: none"> a. Please carefully read this manual before any work is carried out on this inverter, the installation, please keep this manual carefully stored and easy to access at any time. b. The qualified personnel should have had training in the installation and commissioning of the electrical system as well as dealing with hazards, also they should have the knowledge of the manual and other related documents. As the installer or operator they are required to be familiar with local regulations and directives.

2 Production Introduction

2.1 Product Overview

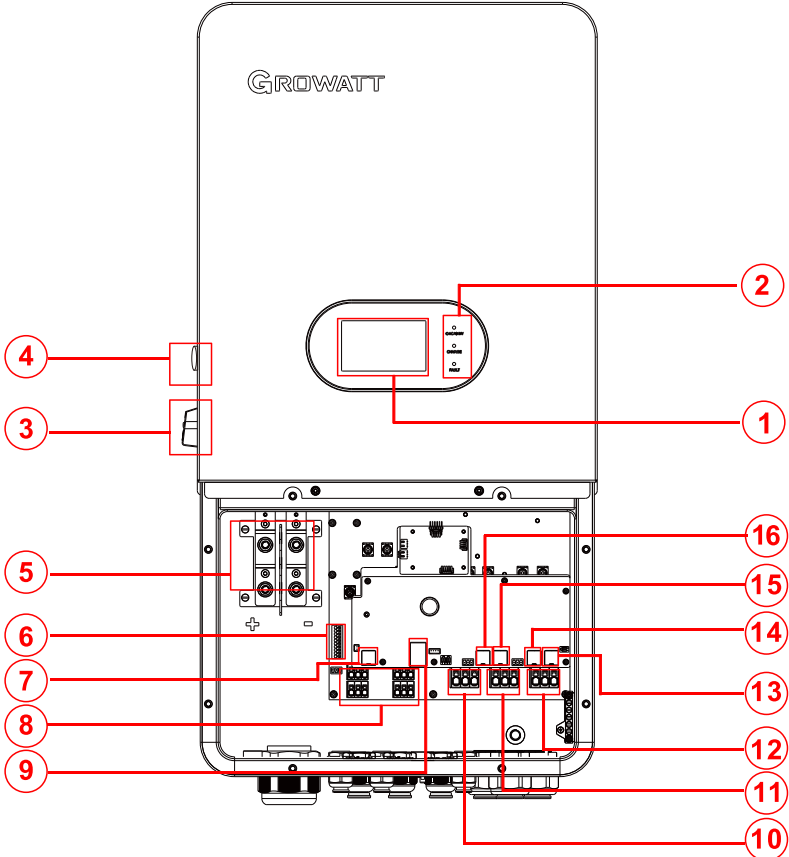

- | | |
|------------------------|-------------------------|
| 1: LCD Display | 9: Upgrading Port(USB) |
| 2: Inverter Indicators | 10: Grid Port |
| 3: PV Switch | 11: Generator Input |
| 4: Power ON/OFF Button | 12: Load Port |
| 5: Battery Input | 13: Parallel-A Port |
| 6: Function Port | 14: Parallel-B Port |
| 7: DRMS Port | 15: Upper Computer Port |
| 8: PV Input | 16: BMS Port |

2.2 Function Port Definition

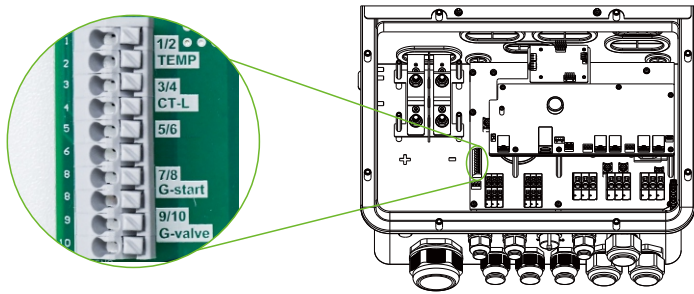

TEMP (1,2): Battery temperature sensor for lead acid battery.

CT-L (3,4): Current transformer (CT) for "Zero Export Limit" mode clamps on L when in single phase system.

G-start (7,8): Generator start signal should be connected to the CON board CN9 terminal 7/8 position, G-start nominal open circuit. If the user wants to start the generator, G-start nominally closes the port.

G-valve (9,10): Reserved.

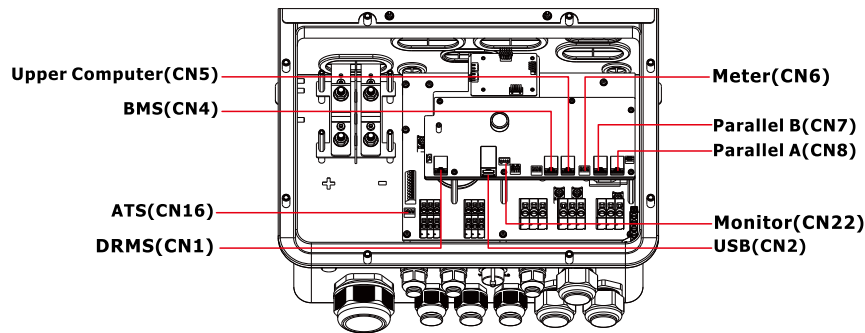
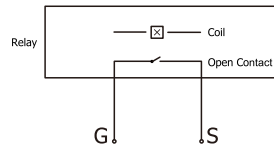

ATs (CN16): 230V output port when inverter is on.

BMS (CN4): RS 485 (1B,2A),CAN (4H,5L) port for battery communication.

Parallel A (CN8): Parallel communication port 1 (CAN interface).

Parallel B (CN7): Parallel communication port 2 (CAN interface).

Meter (CN6): For energy meter communication.

Monitor (CN22): Collector port.

Upper Computer (CN5): Upper Computer Port.

DRMS (CN1): Control the selling and charging power of inverters.

2.3 Product Size

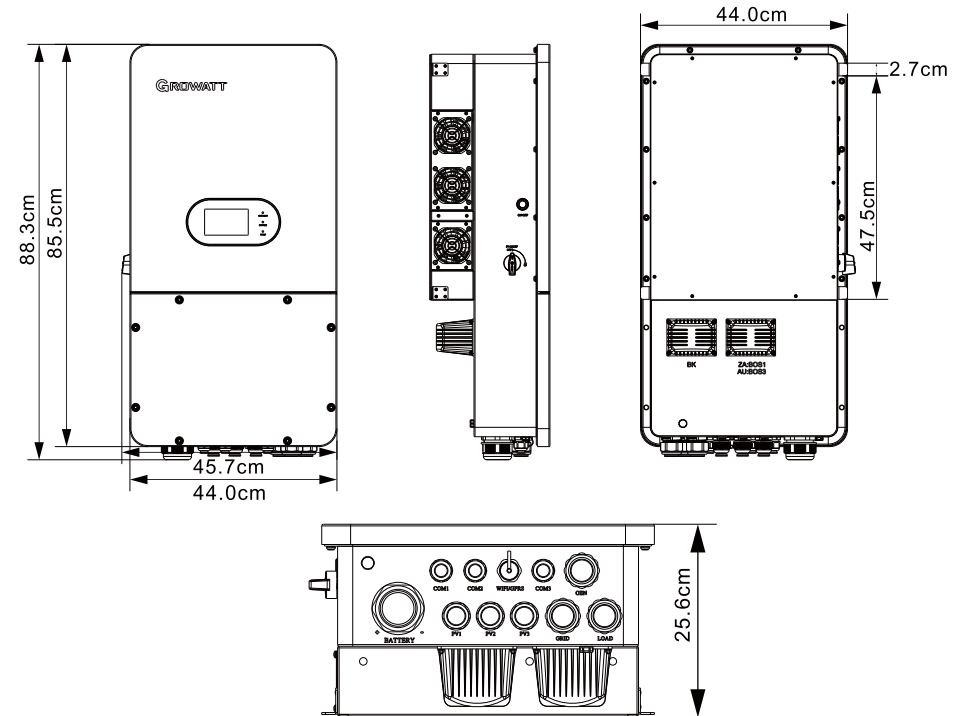

2.4 Product Features

- Supports 230Vac Single Phase, 230/400Vac Three Phase System.
- Self-consumption and export to the grid.
- Configurable battery charging current/voltage based by touch screen setting.
- Configurable AC/Solar/Generator Charger priority by touch screen setting.
- Hybrid inverter Support for connecting to generator.
- AC power loss restart.
- Time of use function.
- Smart battery charger design for optimized battery performance.
- Supporting WiFi/Bluetooth/LAN monitoring and build-in 3 strings of MPPT.
- Smart settable three stages MPPT charging for optimized battery performance.
- Overload/Over temperature/Short circuit protection.
- Programmable supply priority for battery or grid.
- Programmable multiple operation modes: On Grid Mode, Self-consumption Mode, Zero Export Limit.

2.5 Basic System Architecture

The following illustration shows basic application of this inverter.

It also includes following devices to have a complete running system.

- Generator or Utility
- PV modules

Consult with your system integrator for other possible system architectures depending on your requirements.

This inverter can power all kinds of appliances in home or office environment, including motor type appliances such as refrigerator and air conditioner.

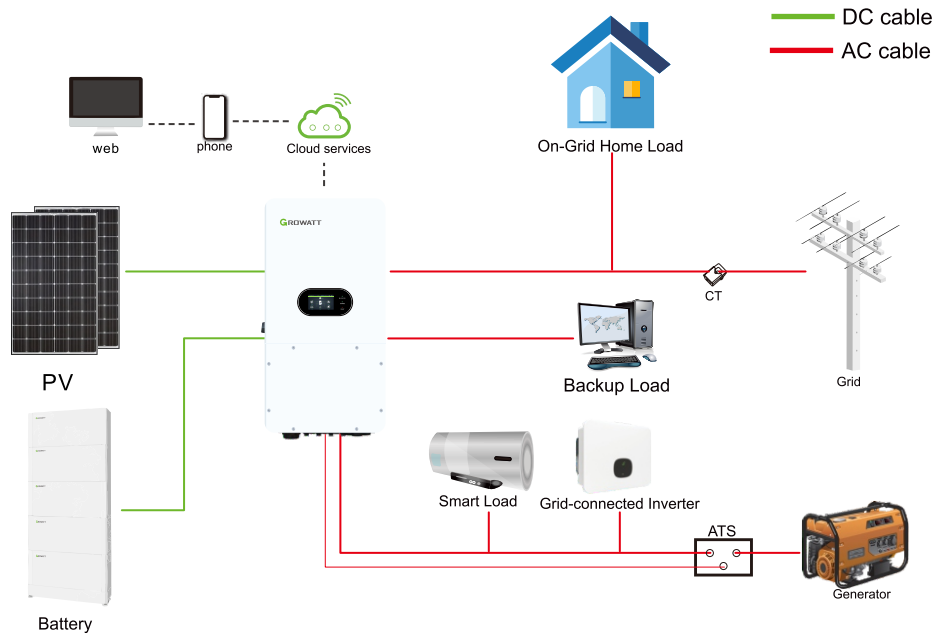

3 Installation

3.1 Parts List

Check the equipment before installation. Please make sure nothing is damaged in the package.

You should have received the items in the following package:

Parts List			A	B	C	D	E
Item	Description	Qty					
A	Hybrid inverter	1					
B	User manual	1					
C	Wall Bracket	2					
D	L-type Hexagon wrench	1					
E	Stainless steel anti-collision bolt	4					
F	Battery temperature sensor	1					
G	Tubular terminal:6AWG,10AWG	6+12					
H	Monitoring equipment	1					
I	Fuse	1					
J	Parallel communication cable	2					
K	Mounting template	1					
L	Sensor Clamp	1					
M	ATS terminal	1					
N	Battery terminal	2					

3.2 Mounting Instructions

Installation Precaution

This hybrid inverter is designed for outdoor use(IP65), please make sure the installation site meets below conditions:

- Not in direct sunlight.
- Not in areas where highly flammable materials are stored.
- Not in potential explosive areas.
- Not in the cool air directly.
- Not near the television Antenna or antenna cable.
- Not higher than altitude of about 2000 meters above sea level.
- Not in environment of precipitation or humidity(>95%).

Considering the following before selecting where to install:

- Please select a vertical wall with load-bearing capacity for installation, suitable for installation on concrete or other non-flammable surfaces, installation is shown below.
- Install this inverter at eye level in order to allow touch screen display to be read at all times.
- The ambient temperature should be between -25~60°C to ensure optimal operation.
- Keep the inverter at a distance from other objects and surfaces as shown below.

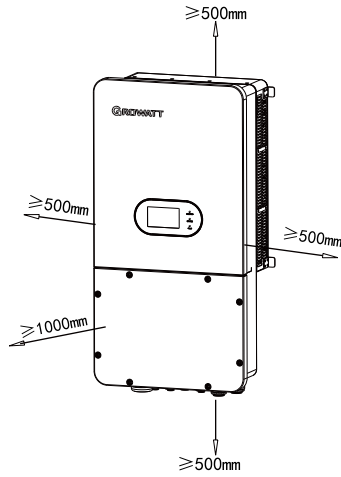

-For proper air circulation to dissipate heat, allow a clearance of approx.50cm to the side and approx.50cm above and below the unit. And 1000mm to the front.

Mounting the inverter

Remember that this inverter is heavy! Caution when lifting out from the package.

- 1.Please make sure that the thickness of the wall for inverter installation is more than 70mm.
- 2.Please place the template horizontally on the wall and confirm the level by level.

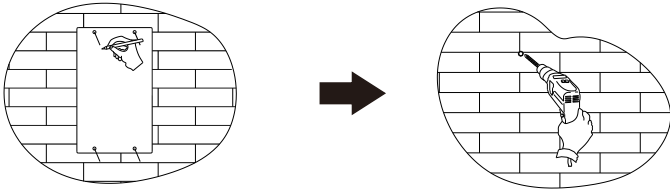

- 3.Please mark the holes in the 4 mounting holes of hole pattern.
- 4.Drill a hole with a depth of 65mm at the mark with a drill of 12mm.

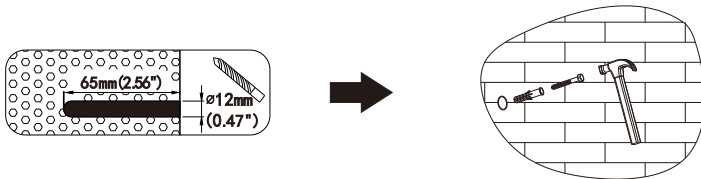

- 5.Please knock the expansion screw rubber sleeve into the hole on the wall, and then screw on the Expansion screw.
- 6.Please hang the inverter on the expansion screws, and then tighten the expansion screws.

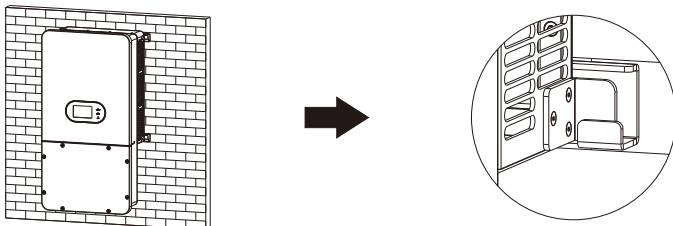

3.3 Battery Connection

For safe operation and compliance, a separate DC over-current protector or disconnect device is required between the battery and the inverter. In some applications, switching devices may not be required but over-current protectors are still required.

Model	Wire Size
SPM 8000-10000TL-HU	2/0AWG or 4/0AWG



WARNING

All wiring must be performed by a professional person. Connecting the battery with a suitable cable is important for safe and efficient operation of the system. To reduce the risk of injury, refer to chart for recommended cables.

SPM 8-10kTL-HU has two battery input ports, so you could choose to connect one battery cluster or two clusters to it. Please follow below steps to implement battery connection:

- 1.Please choose a suitable battery cable with correct connector which fits into the battery terminals.
- 2.Use a philips screwdriver to unscrew the bolts and fit the battery connectors in, then fasten the bolt by the screwdriver, make sure the bolts are tightened in clockwise direction.
- 3.Make sure polarity at both the battery and inverter is correctly connected.

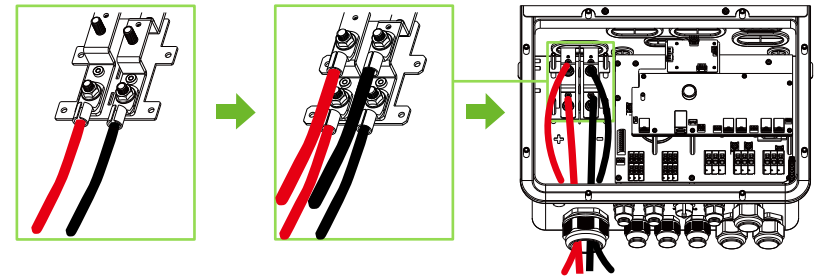

Temperature sensor connection for lead-acid battery.

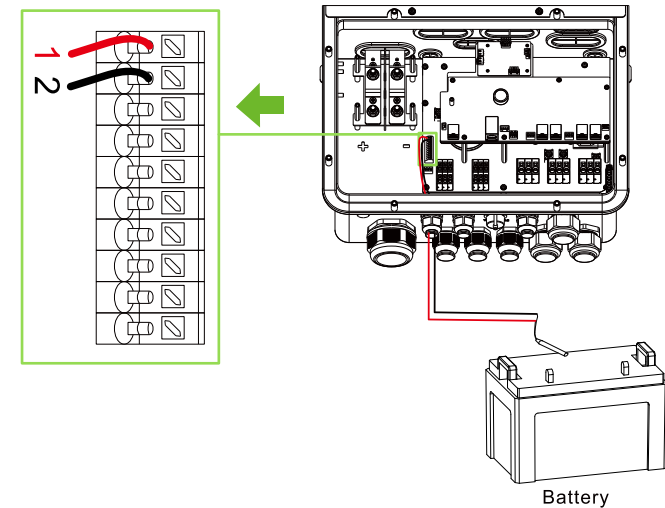

3.4 Grid Connection and Backup Load Connection

Before connecting to grid, please install a separate AC breaker between inverter and grid. Also, it is recommended to install an AC breaker between backup load and inverter. This will ensure the inverter can be securely disconnected during maintenance and fully protected from over current.

There are three terminal blocks with "Grid" "Load" and "GEN" markings. Please do not disconnect input and output connectors.

 WARNING	All wiring must be performed by a qualified personnel. It is very important for system safety and efficient operation to use appropriate cable for AC input connection. To reduce risk of injury, please use the proper recommended cable as below.
--	--

Model	Wire Size
SPM 8000-10000TL-HU	6 AWG

Please follow below steps to implement AC input/output connection:

1. Before making grid, load and gen port connection, be sure to turn off AC breaker first.
2. Remove insulation sleeve 10 mm for positive and negative conductors.
3. Use crimping pliers to press the 6AWG cable onto the attached tubular terminal to form a square.
4. Install the AC conduit to the AC grid output opening (Grid, GEN, Load). Use appropriate conduit fittings and bond where necessary.
5. Terminate the AC conductors to the appropriate terminal.

L	N	L	N	L	N
Grid		GEN		Load	
CN4		CN5		CN6	

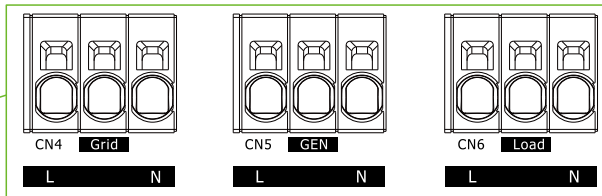
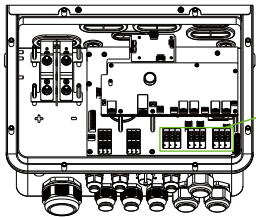

 NOTICE	Be sure that AC power source is disconnected before attempting to wire it to the unit.
---	---

Appliances such as air conditioner are required at least 2-3 minutes to restart because it is required to have enough time to balance refrigerant gas inside of circuit. If a power shortage occurs and recovers in short time, it will cause damage to your connected appliances. To prevent this kind of damage, please check manufacturer of air conditioner if it is equipped with time-delay function before installation. Otherwise, this inverter will trigger overload fault and cut off output to protect your appliance but sometimes it still causes internal damage to the air conditioner.

3.5 PV Connection

Before connecting to PV modules, please install a separate DC circuit breaker between inverter and PV modules. It is very important for system safety and efficient operation to use appropriate cable for PV module connection. To reduce risk of injury, please use the proper recommended cable size as below.

Model	Wire Size
SPM 8000-10000TL-HU	10AWG

 WARNING	To avoid any malfunction, do not connect any PV modules with possible current leakage to the inverter. For example, grounded PV modules will cause current leakage to the inverter. When using PV modules, please be sure no grounding. It is requested to use PV junction box with surge protection. Otherwise, it will cause damage on inverter when lightning occurs on PV modules.
--	---

3.5.1 PV Module Selection

When selecting proper PV modules, please be sure to consider below parameters:

1. Open circuit Voltage (Voc) of PV modules should not exceed max PV array open circuit voltage of inverter.
2. Open circuit Voltage (Voc) of PV modules should be higher than min start voltage.

Inverter Model	SPM 8000-10000TL-HU
PV Input Voltage	370V(130V-550V)
PV Array MPPT Voltage Range	150V-500V
No. of MPPT Trackers	3
No. of Strings per MPPT Tracker	2+2+2

3.5.2 PV Module Wire Connection

Please follow below steps to implement PV module connection:

1. Remove insulation sleeve 10 mm for positive and negative conductors.
2. Use crimping pliers to press the 10AWG cable onto the attached tubular terminal to form a square.
3. Check correct polarity of wire connection from PV modules and PV input connectors. Then, connect positive pole (+) of connection wire to positive pole (+) of PV input connector. Connect negative pole (-) of connection wire to negative pole (-) of PV input connector. PV3 requires two 10AWG wires to be inserted into the upper and lower terminals. Close the switch and make sure the wires are tightly fixed.
4. Parallel strings per MPPT must be the same voltage.
 - a. PV1 A/B must be the same voltage if using both strings.
 - b. Panels of the same MPPT can be installed in the same orientation, while panels of different MPPTs can be installed in different orientations.

5. Terminate the PV string to the appropriate terminal.

	Make sure the wire is tight and secure				
--	---	--	--	--	--

1	2	3	4	5	6
PV1+	PV2+	PV3+	PV1-	PV2-	PV3-
PV1+	PV2+	PV3+	PV1-	PV2-	PV3-

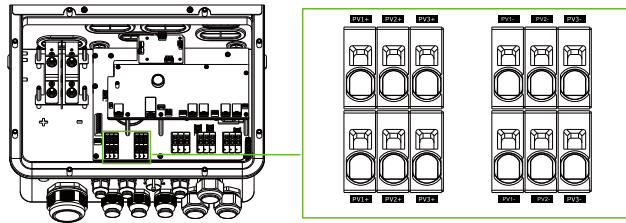

3.6 Meter or CT Connection

Meter Connection

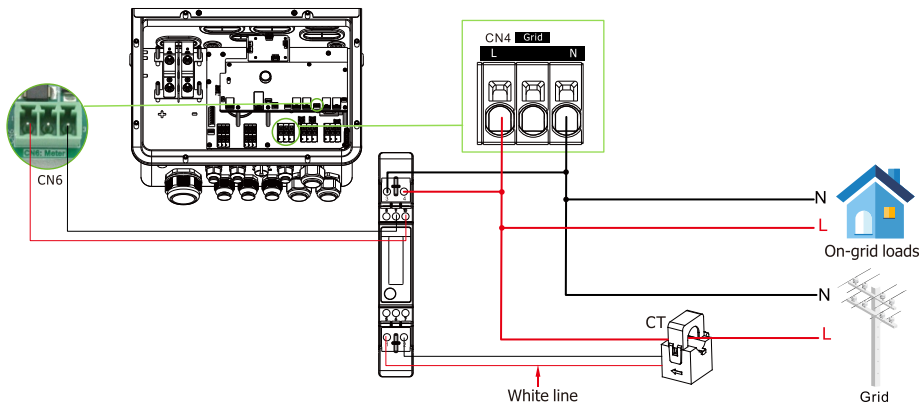

CT Connection

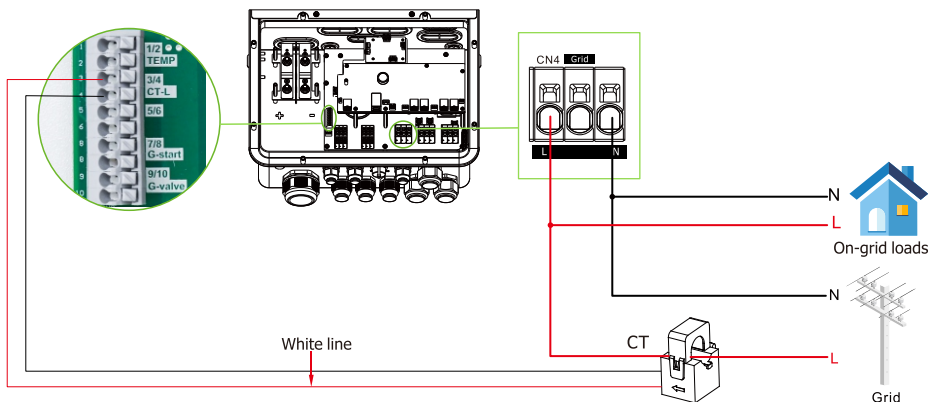

3.7 Earth Connection

Ground cable shall be connected to ground plate on grid side this prevents electric shock, if the original protective conductor fails.

Model	Wire Size
SPM 8000-10000TL-HU	12AWG

Please follow below steps to implement ground cable connection:

1. Remove insulation sleeve 10 mm for wire.
2. Loosen the screw, insert the ground wire and then tighten the screw. Please make sure that the ground cable is firmly connected to the ground bar.

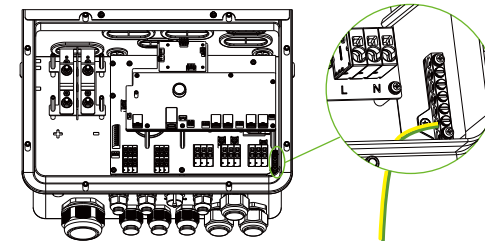

3.8 Dip Switch Status

Working condition	Switch status
Connect to the collector(Default)	1/2:ON; 3/4→OFF
Local upgrade	1/2:ON; 3/4→OFF

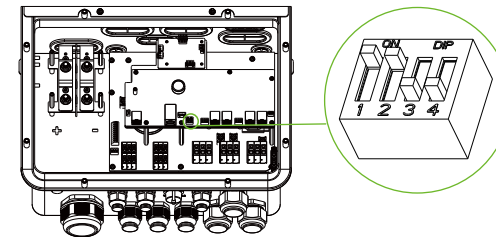

3.9 Fan Replacement

Please check and clean the fans regularly. The recommended period is 6 months.

Please replace the fan following up the below diagram if there is problem with the fans. Turn off the system and wait for more than 5 minutes before disassembling the machine.

a. Loosen the screws and remove them.

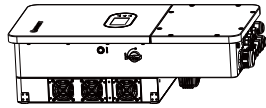

b. Remove the fan fixing.

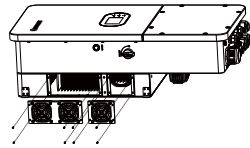

c. Pull out the fan bracket completely, and use a soft brush to clean the fan or replace a damaged fan.

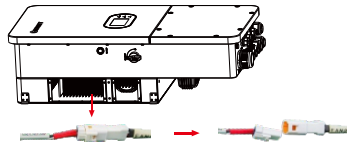

d. Remove the fan and replace it.

e. After the fan is installed, follow the steps just now to push back and assemble it back.

3.10 Wiring System for Inverter

SPM 8000-10000TL-HU (AU)

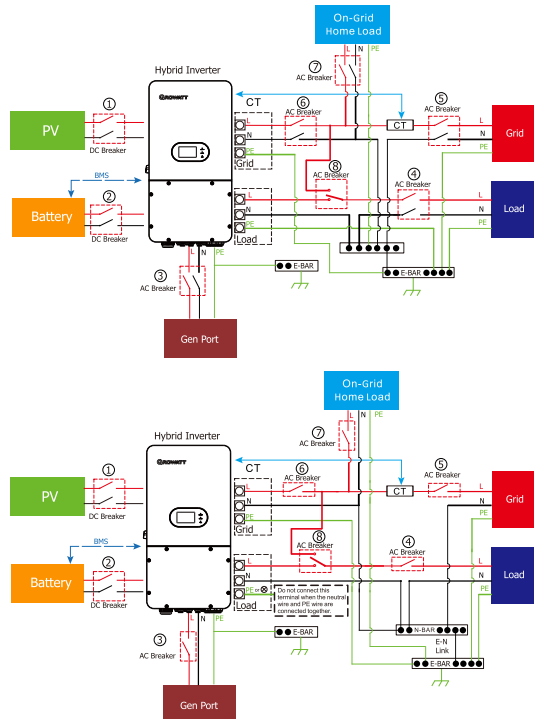

SPM 8000-10000TL-HU (EU/UK)

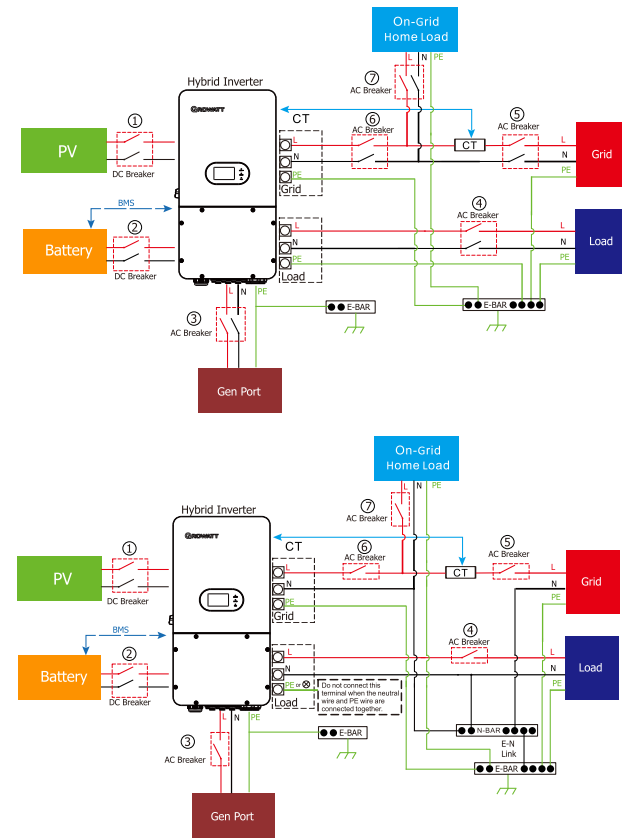

Breakers selection recommendation for both DC and AC.

Inverter Model	SPM 10000TL-HU	SPM 8000TL-HU
PV Breakers(①)	600V/24A (PV3 600V/40A)	600V/24A (PV3 600V/40A)
Battery Breaker(②)	80V/250A	80V/200A
Generator Breaker(③)	230V/63A	230V/52A
Load Breaker(④)	230V/63A	230V/52A
AC Breaker(⑤)	230V/100A	230V/80A
AC Breaker(⑥)	230V/63A	230V/52A
On-Grid Home Load Breaker(⑦)	230V/100A	230V/80A
AC Breaker(⑧)	230V/63A	230V/63A

3.1.1 Single Phase 230Vac Parallel Connection

Three inverters in parallel one-phase:

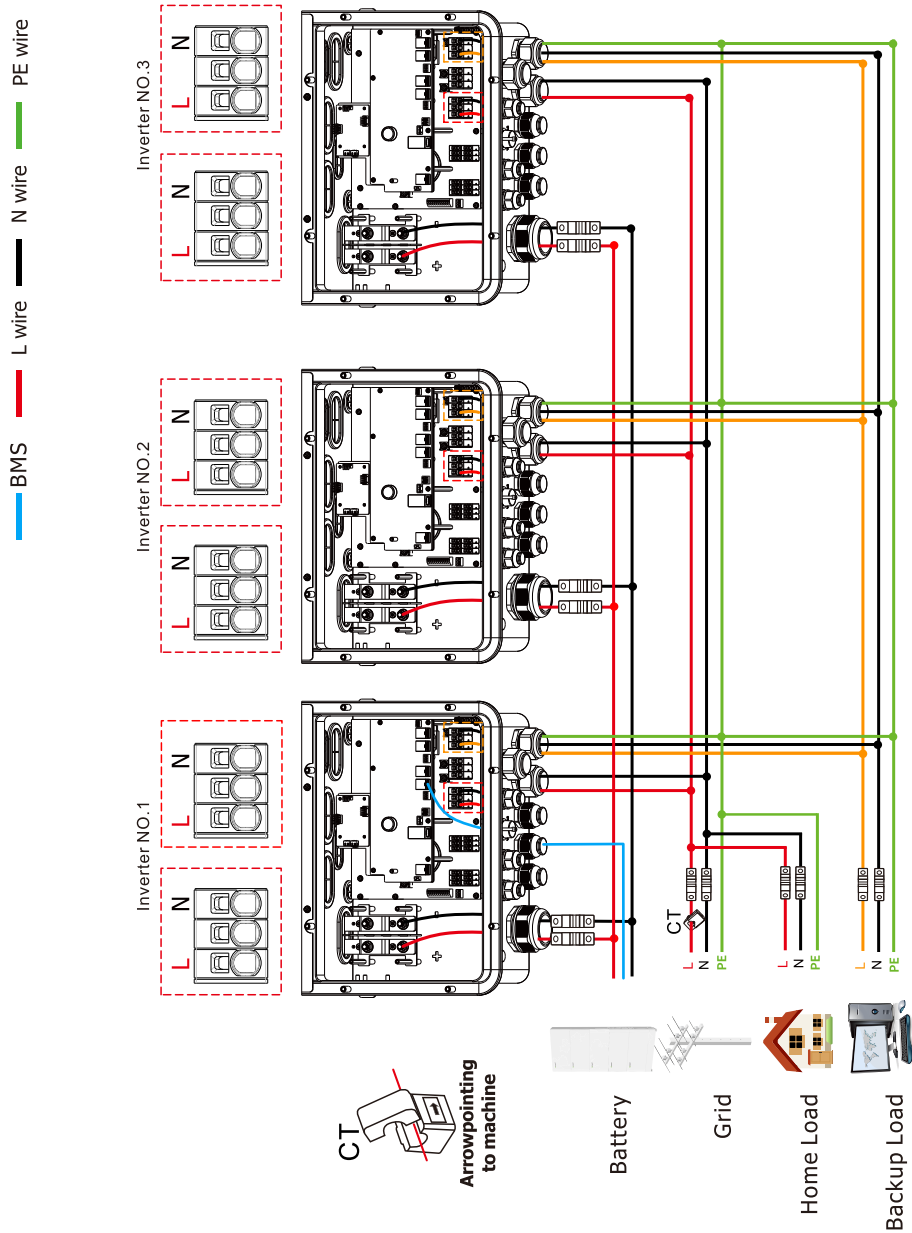

Inverter NO.1

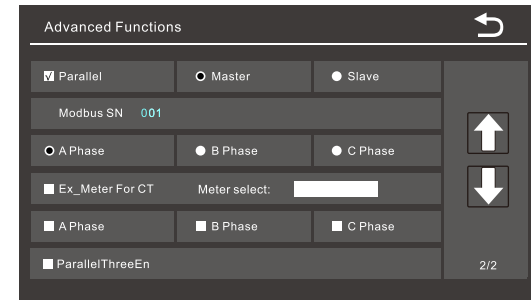

Inverter NO.2

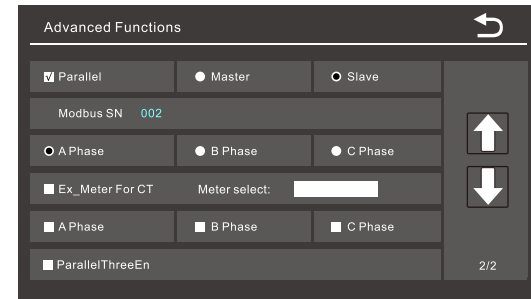

Inverter NO.3

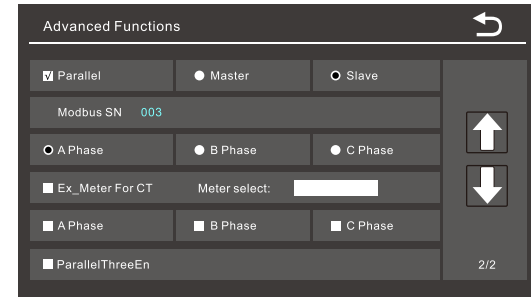

Communication Connection

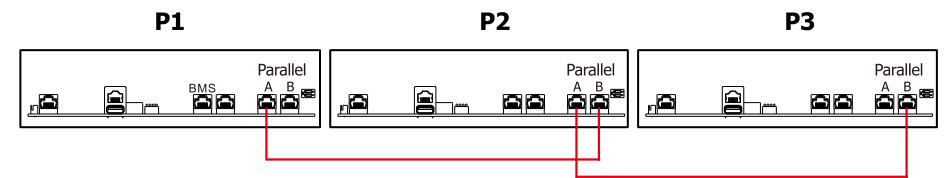

Modbus SN: This feature is currently not being used.

The status of the dip switch needs to be fully turned on.

CT: Connect pins 3 and 4 of L (Inverter NO.1).

Allow for 6 machines to be combined.

3.12 3Pcs Parallel Connection for 230/400Vac Three Phase

Three inverters in parallel three-phase:

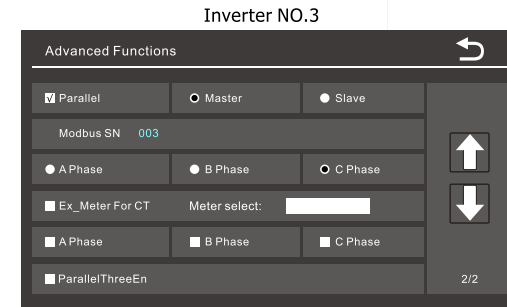
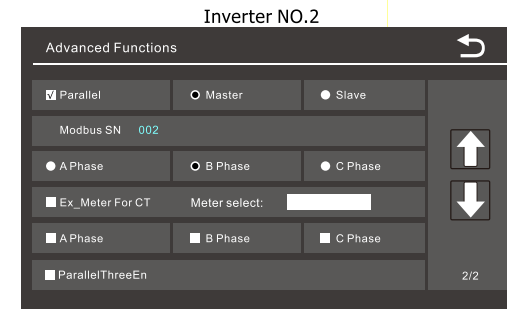
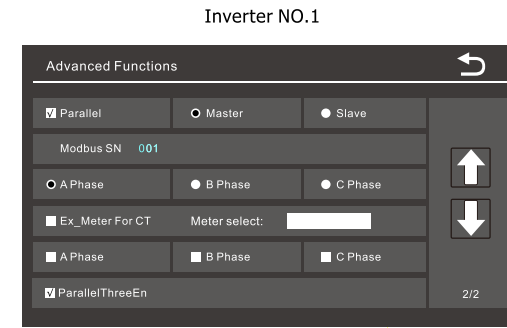
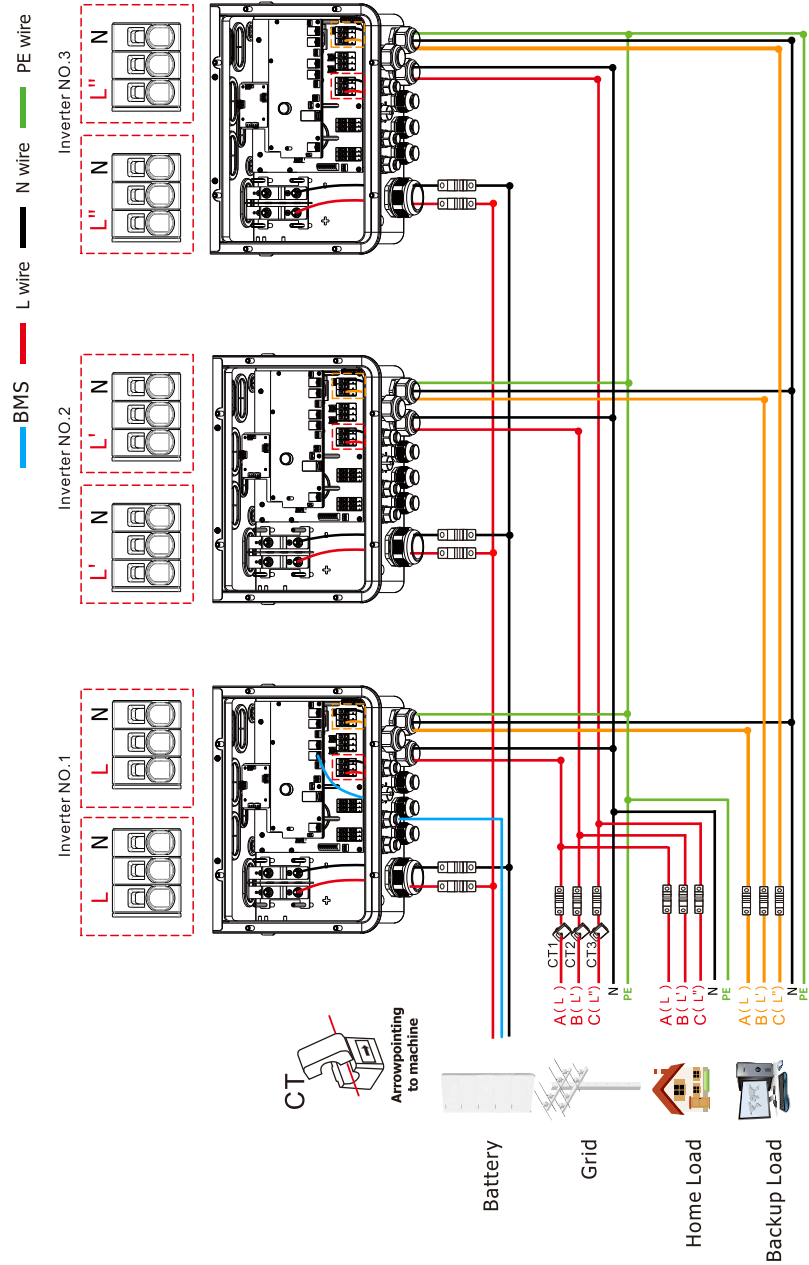

Communication Connection

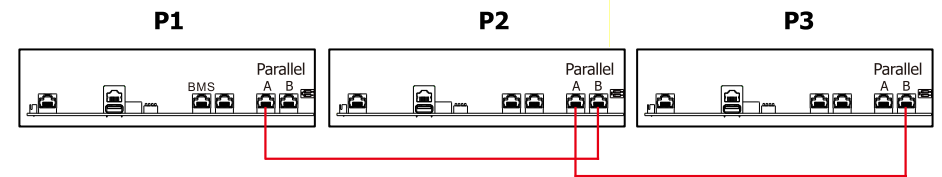

Modbus SN: This feature is currently not being used.

The status of the dip switch needs to be fully turned on.

CT1: Connect pins 3 and 4 of L (Inverter NO.1).

CT2: Connect pins 3 and 4 of L' (Inverter NO.2).

CT3: Connect pins 3 and 4 of L'' (Inverter NO.3).

3.13 6Pcs Parallel Connection for 230/400Vac Three Phase

Six inverters in parallel three-phase:

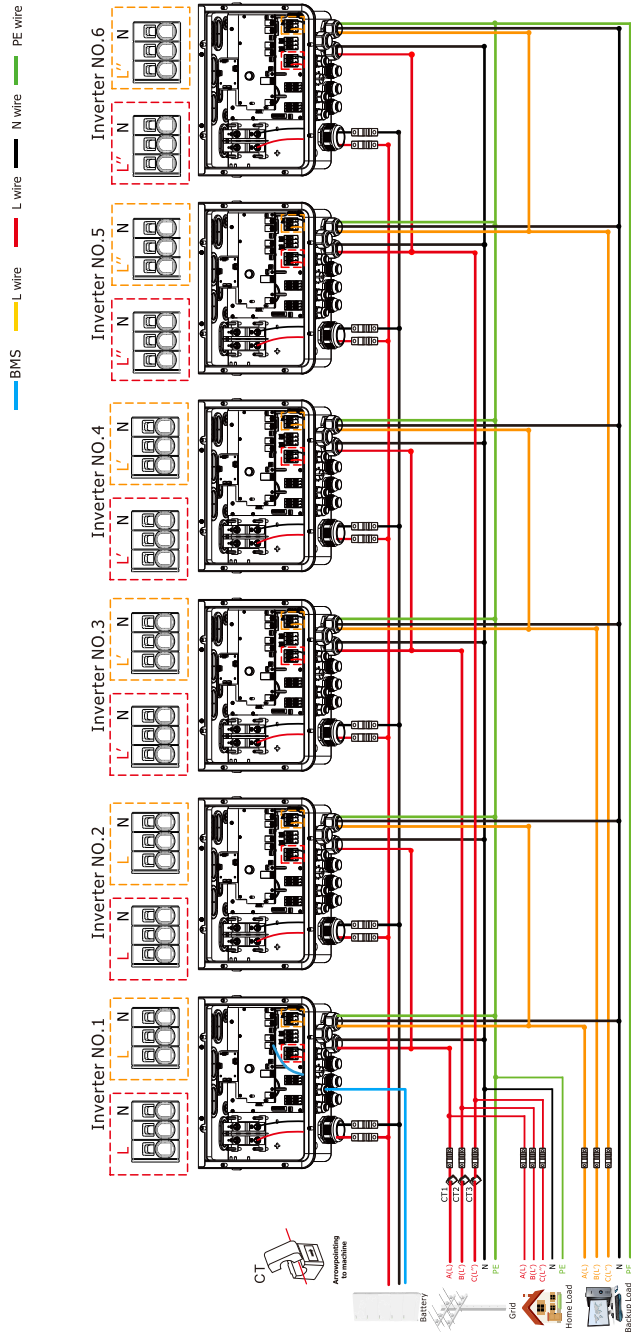

Inverter NO.1

Advanced Functions

Parallel Master Slave

Modbus SN 001

A Phase B Phase C Phase

Ex_Meter For CT Meter select: _____

A Phase B Phase C Phase

ParallelThreeEn 2/2

Inverter NO.2

Advanced Functions

Parallel Master Slave

Modbus SN 002

A Phase B Phase C Phase

Ex_Meter For CT Meter select: _____

A Phase B Phase C Phase

ParallelThreeEn 2/2

Inverter NO.3

Advanced Functions

Parallel Master Slave

Modbus SN 003

A Phase B Phase C Phase

Ex_Meter For CT Meter select: _____

A Phase B Phase C Phase

ParallelThreeEn 2/2

Inverter NO.4

Advanced Functions

Parallel Master Slave

Modbus SN 004

A Phase B Phase C Phase

Ex_Meter For CT Meter select: _____

A Phase B Phase C Phase

ParallelThreeEn 2/2

Inverter NO.5

Advanced Functions

Parallel Master Slave

Modbus SN 005

A Phase B Phase C Phase

Ex_Meter For CT Meter select: _____

A Phase B Phase C Phase

ParallelThreeEn 2/2

Inverter NO.6

Advanced Functions

Parallel Master Slave

Modbus SN 006

A Phase B Phase C Phase

Ex_Meter For CT Meter select: _____

A Phase B Phase C Phase

ParallelThreeEn 2/2

Communication Connection

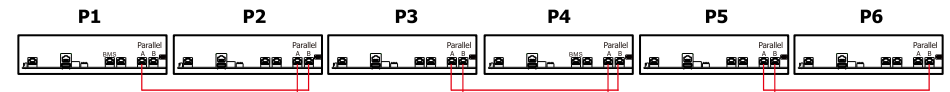

Modbus SN: This feature is currently not b

The status of the dip switch needs to be fully turned on.

CT1: Connect pins 3 and 4 of L (Inverter NO.1).

CT2: Connect pins 3 and 4 of L' (Inverter NO.3).

CT3: Connect pins 3 and 4 of L'' (Inverter NO.5).

4 Operations on the ShineTools APP

4.1 Overview

ShineTools is a smart APP that could realize the inverter system local commissioning function via the smart phone. It communicates with the inverter through internal Bluetooth or data logger to realize real-time status monitoring, alarm query, parameter configuration, intelligent diagnosis and other routine maintenance functions, is a convenient local configuration platform.

- Real-time status monitoring: Captures the real-time status of inverters and data loggers.
- Alarm query: There are easy-to-operate alarm function and flexible alarm display mechanism could help obtain fault location information quickly, and convenience for customers to take countermeasures timely, improve the efficiency of operation and maintenance.
- Parameter configuration: Simple and safe parameter configuration, and one-stop unified configuration can be realized through the data logger.

4.2 APP Download

Scan the QR code or search for "ShineTools" in Google Play or Apple Store to download and install the APP.

How to install an external collector, please scan the QR code on the back of the instruction manual to view.



4.3 Login

Start the APP.

- Choose the end user or O&M account.
- Enter the account and password and log in. End user password is oss+current date.(example April 16,2024 is oss20240416).
- After login successfully, you can check the "Installation Manual".

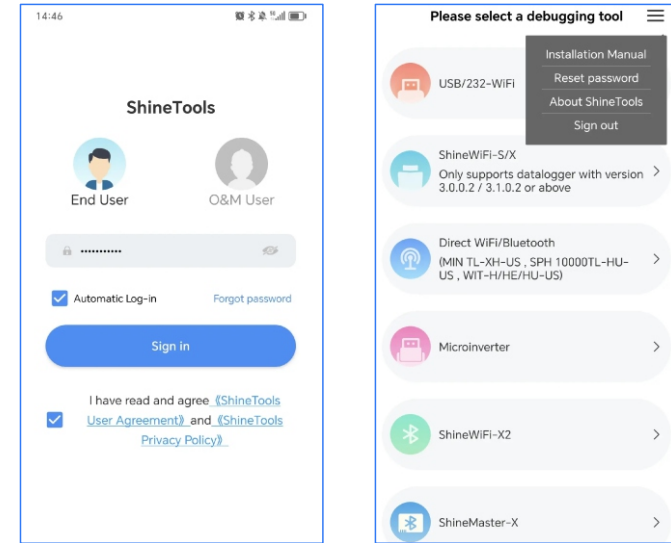

4.4 Direct WiFi/Bluetooth Commissioning Tool

- Select the "Direct WiFi/Bluetooth" channel.
- Select the corresponding model.
- Scan the device serial number barcode on the right side of the inverter to configure Bluetooth. You can also configure Bluetooth by manually entering the device serial number.
- Enter the Local Commissioning interface.

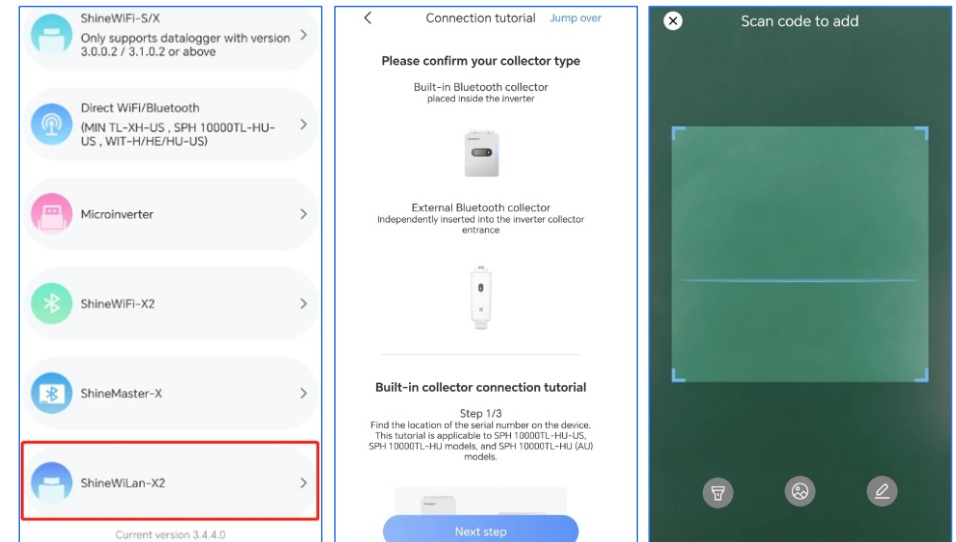

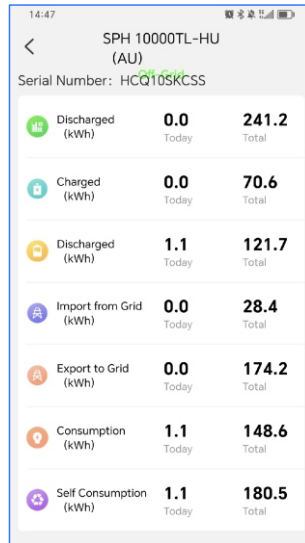
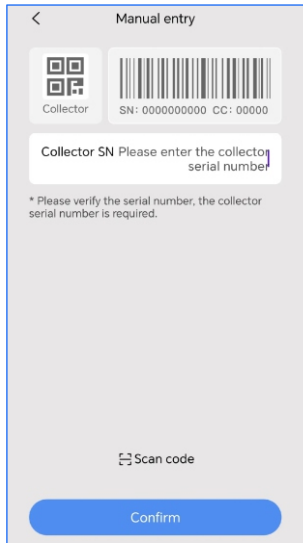

Tips:

The router name and password cannot contain space characters.

Only support English input mode characters.

1.Supported punctuation: . , ? ! : @ ; + = # / () _ - ` ^ * & . \$ < > [] { }.

2.Unsupported punctuation: ... • € ' % ¥ \ .

4.6 Parameter Setting (Specific to the App display setting items)

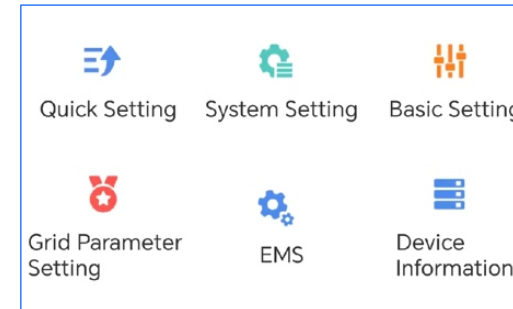

4.5 Commissioning of SPM 10000/8000TL-HU

Local Commissioning> Quick Setting> Network Type

- Select/fill network, enter the password, and select the server address.
- Choose the network configuration method-WiFi.
- Click to connect to the network.

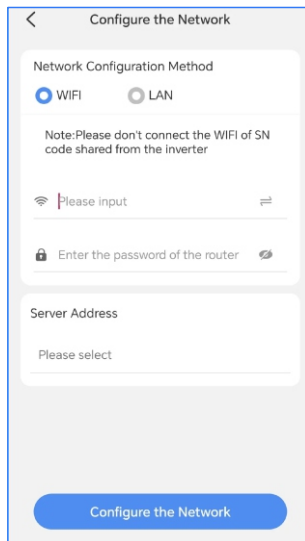
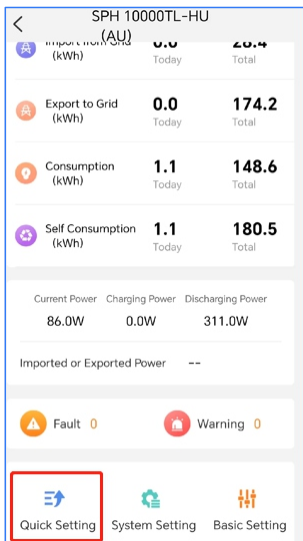

5 Operations on The ShinePhone APP

5.1 Overview

The ShinePhone APP is a mobile phone app that locally communicates with the SPM 10000/8000TL-HU, over WiFi to allow for real-time status monitoring, system mode management, performing routine maintenance, and commissioning. After the PV or Power Grid side of the SPM 10000TL-HU is energized, the APP can connect to the inverter in either of the following ways:

1. The mobile phone is directly connected to the Bluetooth inside the SPM 8000-10000TL-HU for local tools.



2. The mobile phone is connected to the SPM 8000-10000TL-HU inverter through the router. Notice: Do not use this method for the first time. If you need to use this method for remote monitoring and setup, make sure the inverter is connected to the network via the ShineTools (Please refer to 4.5 for the network connection).

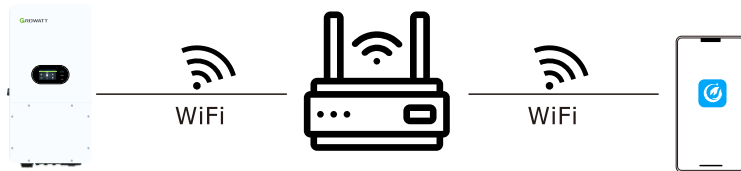

5.2 APP Download

There are three ways to download the ShinePhone APP.

5.2.1 Scan the QR code



Scanning the QR code, then download the APP.

5.2.2 APP Store

Search for ShinePhone from one of the following app stores in the following list, download the installation package, and install the ShinePhone app by following the in instructions.

-Google Play (Android)

-App store (iOS)

5.2.3 Website

Log in to our monitoring website <https://server.growatt.com> to download.

After the app is installed, the ShinePhone icon is displayed on the home screen.



5.3 APP Introduction

5.3.1 Multiple Languages Supported

ShinePhone supports multiple languages. APP language automatically switches according to the user's mobile language.

5.3.2 Local Tool

You can choose to configure the local debugging tool by clicking the tool below the login interface. Use the debugging tool for real-time device control and for device monitoring.

5.3.3 Login to ShinePhone

Connecting to the inverter Collector to allow for real-time status monitoring, system mode management, performing routine maintenance, and commissioning. It's also the first step in remote network configuration.

- Open the ShinePhone app to register an account, log in to your account after registration is complete

-You can switch the App language through the upper right corner.

-Select country and religion.

-Enter username and password.

-Click "Remember Password" to save your password.

-Click to log in to the homepage.

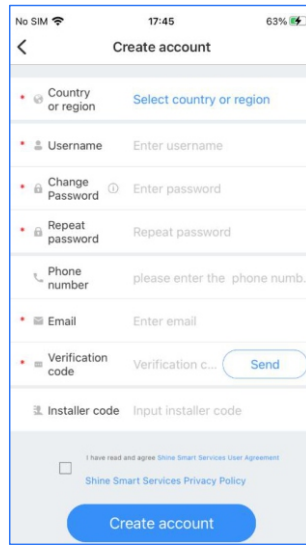
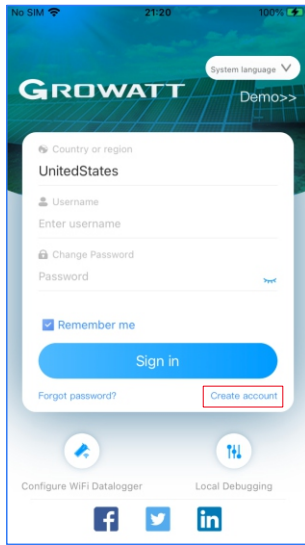

5.3.4 Add power station and collector

-Create a power station after logging in to the homepage (Note: Items marked * are required. Please fill it out correctly.)

-You can add the collector to the corresponding power station by scanning the collector "SN" number (VCxxxxxxx) on the right side of the inverter, or you can enter it manually.

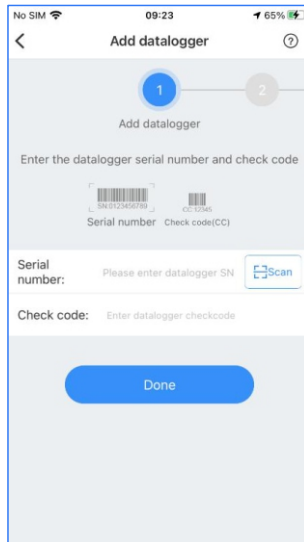
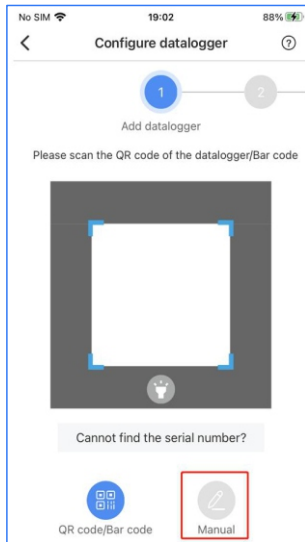
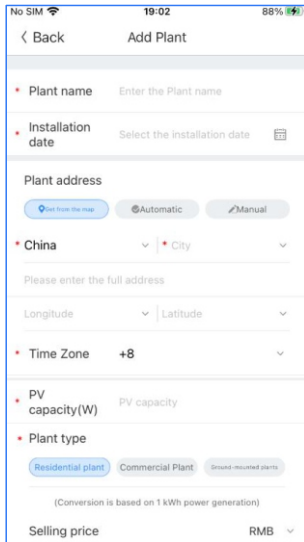

5.3.5 Main interface display and power station list

- After successfully creating a power station and adding a collector, it will automatically jump to the APP main interface.

-Click "Plant" in the lower tab bar to jump to the plant list interface, and click the corresponding plant to view the generation, power and the other parameters of each inverter under each plant.

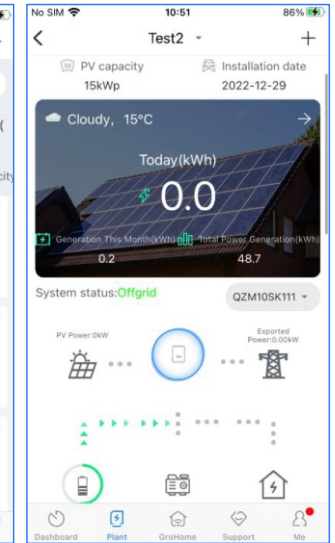
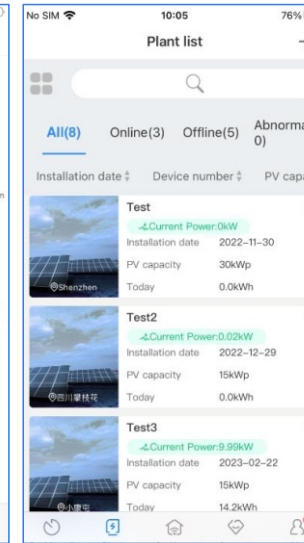
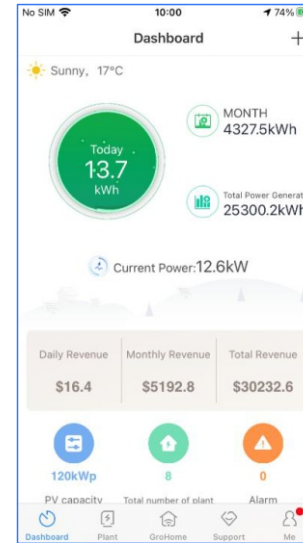

5.3.6 Details and parameter settings in the power station

-If you need to add, view, delete the datalogger or add a plant, please click the "+" in the upper right corner.

Note: If the datalogger needs to change the account monitoring, you need to delete the datalogger under the original account, then add the datalogger under the new account.

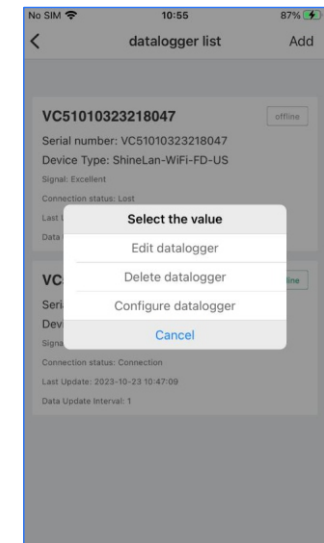
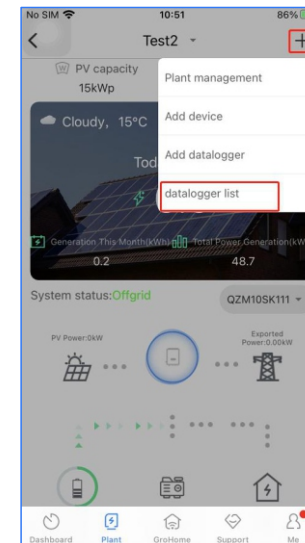

- Click "→" to modify the power station details (for example: power station name, photovoltaic components, etc.)

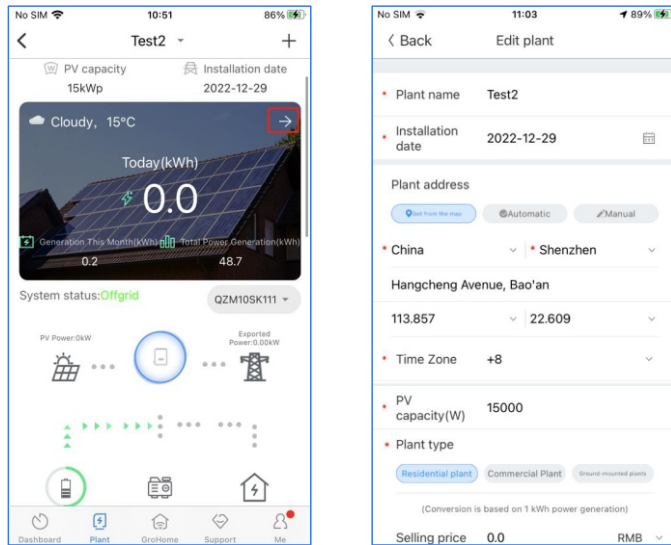

- Click "!" to quickly view the current working data of the inverter (Solar voltage/Battery voltage/Grid voltage/Grid frequency/Output voltage/Output frequency).

- Click the fault icon in the lower right corner to display the current machine fault information details.

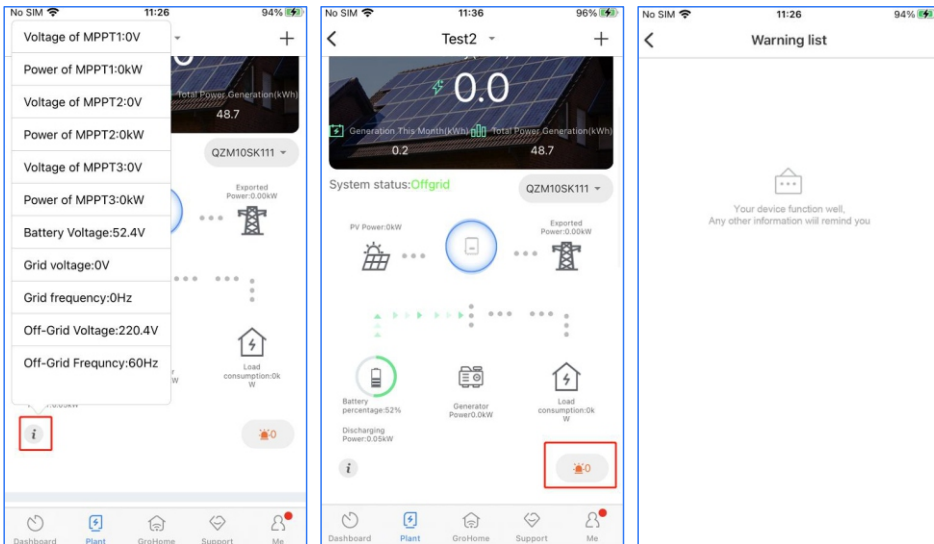

- Drag the screen down to see the energy trend graph. This interface can view the current power, SOC usage (only in lithium battery mode) and battery charge and discharge energy. You can also view the daily, monthly, and annual photovoltaic output/feed into the grid/load consumption/grid power withdrawal/self-consumption cumulative electricity.

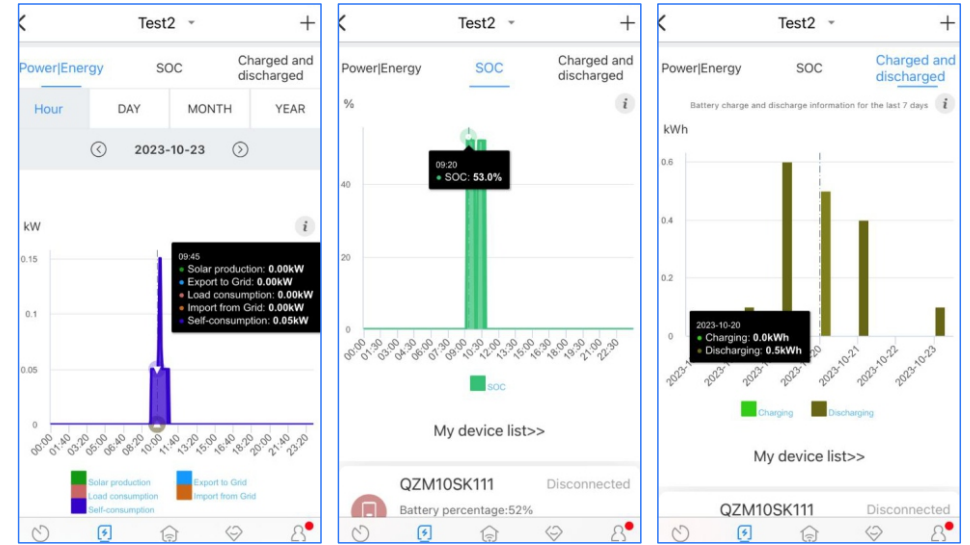

-In the My device list at the bottom of the interface, you can view the status (signal strength, refresh time, etc.) of all collectors added to the power station.

-You can also enter the detailed parameter reading and control interface of the inverter according to the device serial number.

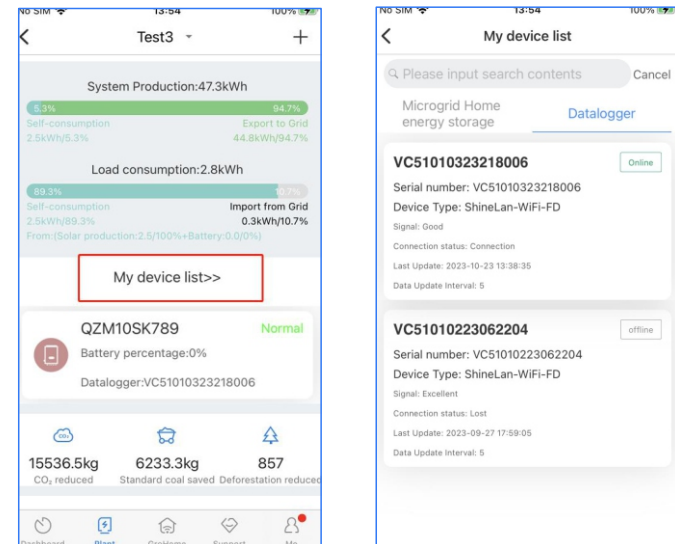

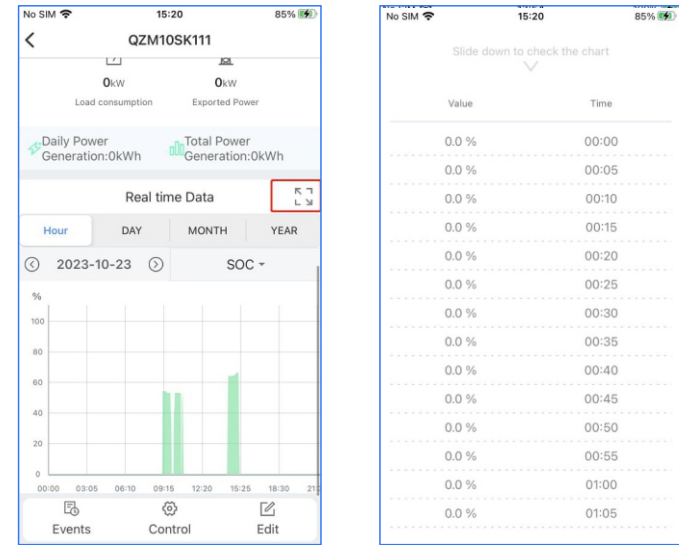
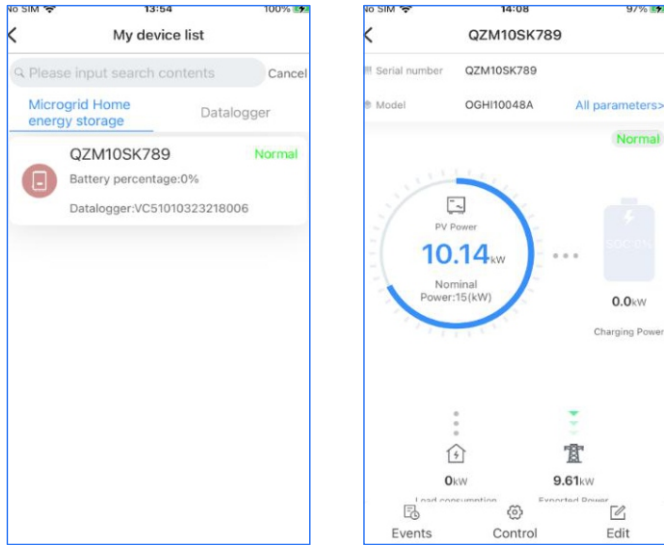

- This interface can display the real-time status of the data, and you can also view the detailed parameters of the inverter, solar energy, grid, battery, and load under the working status of the device, as well as the basic parameters of the device itself (For example: serial number, model, firmware version...).

-In the log at the bottom of the interface, you can view the device's historical fault records and fault details.

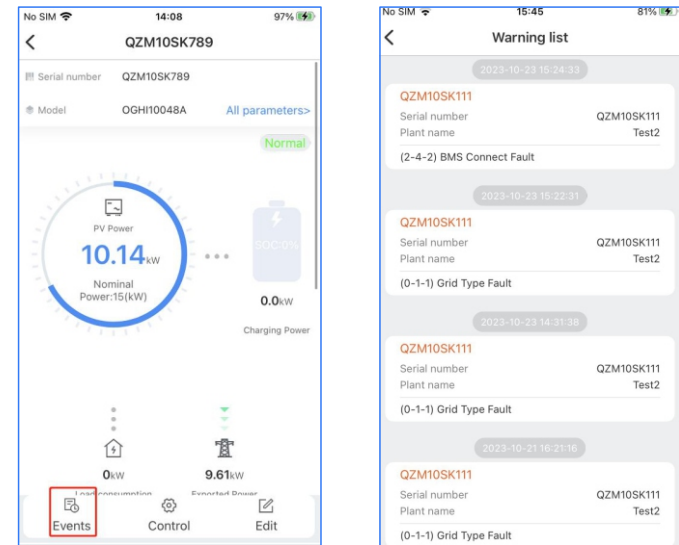
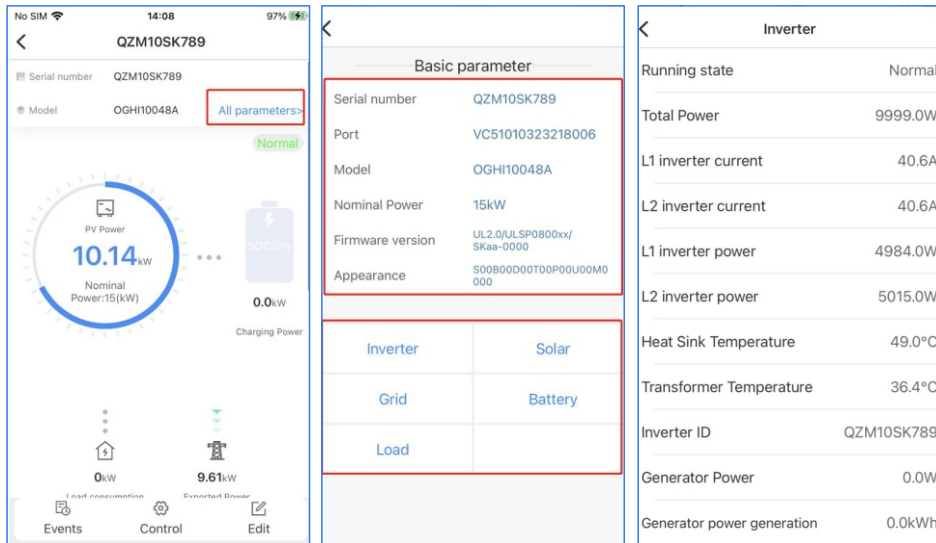

- Energy trend graphs can also be found here. For more details, we can click on the icon in the upper right corner to view it.

- Equipment control interface: Users can turn on and off the machine on the equipment control interface. Set the maximum charging current, maximum discharge current, inversion time, grid voltage upper limit, grid voltage Lower limit etc. The password is: growatt + current date.(Notice: Do not change parameters at will as this may cause your inverter to malfunction.)

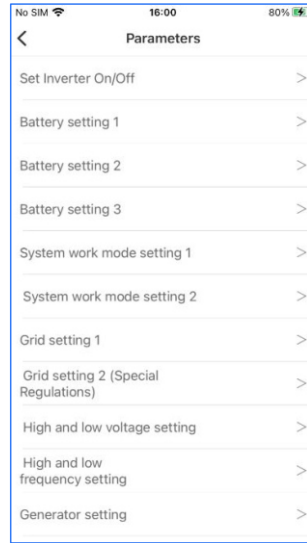

Device editing page: Users can edit device aliases and delete devices.

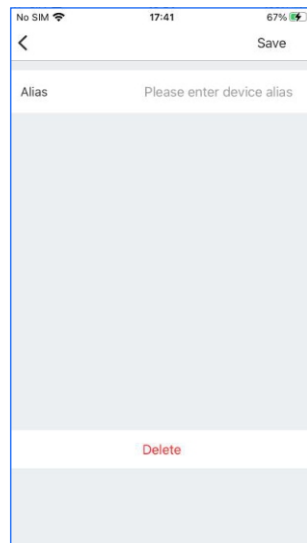
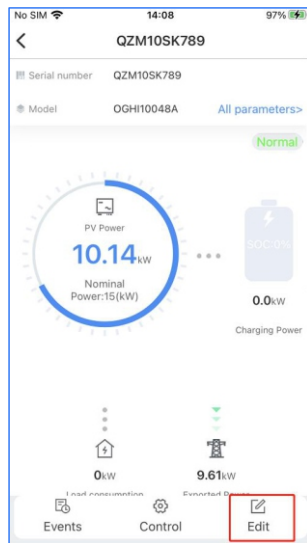

6 Operation

6.1 Power ON/OFF

Once the unit has been properly installed and the batteries are connected well, simply press On/Off button (located on the left side of the case) to turn on the unit. When one of the grid or PV is connected the screen will still light up even if the battery is not connected, in this condition, the system can still work normally when switch on the ON/OFF button and select no battery mode.

6.2 Operation and Display Panel

The operation and display panel, shown in below chart, is on the front panel of the inverter. It includes three indicators and a touch screen display, indicating the operating status and input/output power information.

LED Indicator		Messages	
AC/INV	GREEN	Light	Powered by AC
		Twinkle	Powered by DC
CHARGE	GREEN	Light	Full battery
		Twinkle	Charging
FAULT	RED	Light	Error
		Twinkle	Warning

7 Main Screen

7.1 Touch Screen Operation Flow Chart

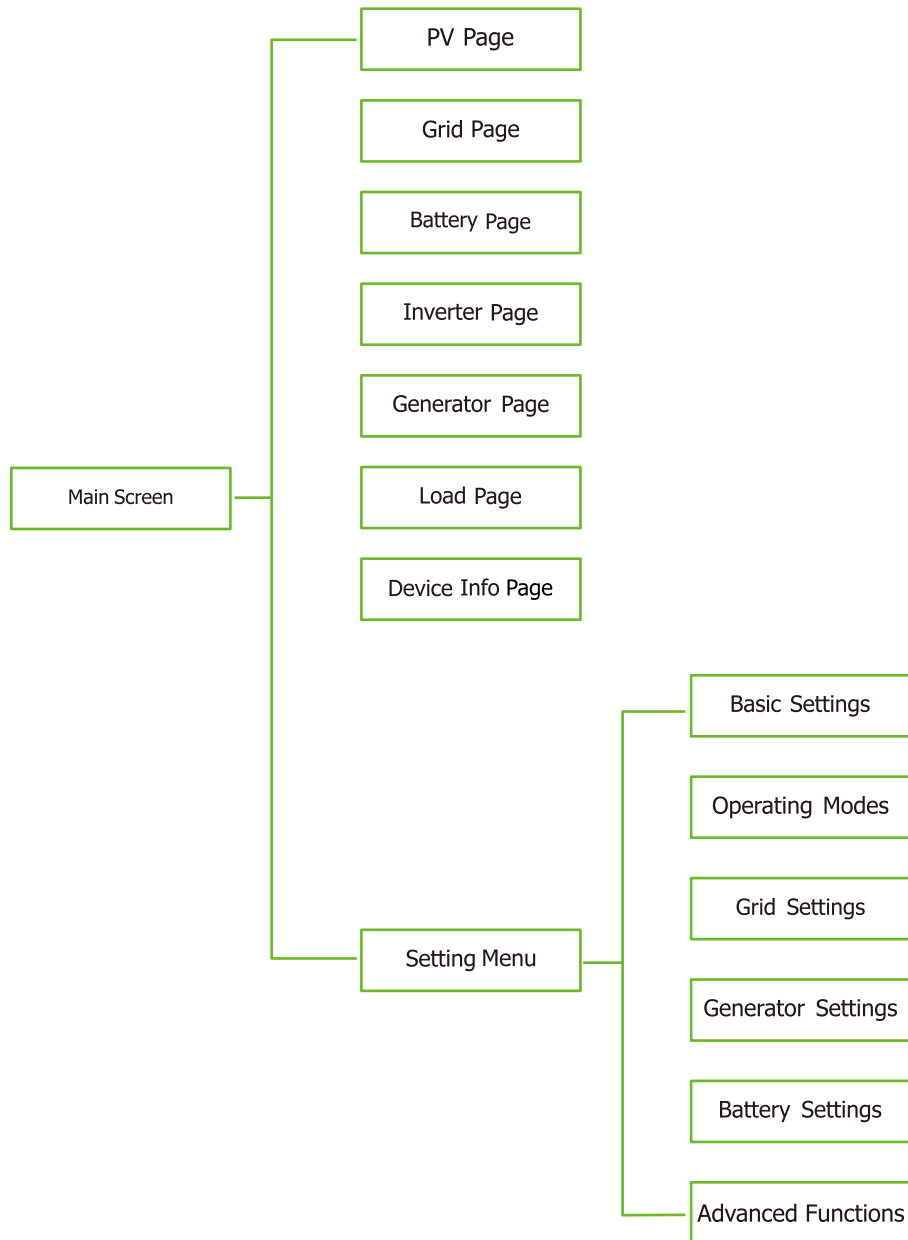

7.2 Main Screen

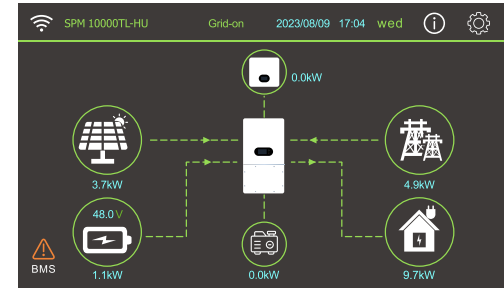

Icon	Description
	PV
	Battery: Battery Power, Charge(negative), Discharge(positive)
	Inverter
	Generator
	Setting Menu
	Grid: Grid Power ,Export(negative), Import(positive)
	Load
	BMS communication error
	WiFi

- The "Grid-on" in the above of the home screen indicates that the system is Normal operation. If "Fault: F17-64 or Alarm: W01-W96" appears in the upper left corner of the screen, a communication error or other error has occurred in the inverter. F17-F64 faults and W01-W96 alarms, detailed information can be found in the exclamation mark in the upper right corner of the main screen.
- At the top of the screen is the time.
- Setting Menu Icon, press this set button, you can enter into the system setup screen which including Basic Settings, Operating Modes, Grid Settings, Generator Settings, Battery Settings and Advanced Functions.
- The main screen showing the info including Solar, Grid, Load and Battery. It also displaying the energy flow direction by arrow.
 - PV power and Load power always keep positive.
 - Grid power negative means sell to grid, positive means get from grid.
 - Battery power negative means charge, positive means discharge.
- When there is an abnormal BMS communication, a BMS alarm icon will appear in the bottom left corner of the screen, After this alarm occurs, the lithium battery automatically switches to lead-acid batter, but cannot becharged.

PV Detail Page

PV			
Power	618 W		
PV1-P	208 W	PV2-P	205 W
PV3-P	206 W		
PV1-V	364.8 Vdc	PV2-V	361.1 Vdc
PV3-V	361.7 Vdc		
PV1-I	0.5 Adc	PV2-I	0.5 Adc
PV3-I	0.5 Adc		
Today	0.9 kWh	Total	260.8 kWh

Solar Panel Generation.
Power,Voltage,Current for each MPPT.
Solar panel energy for Day and Total.

Grid Detail Page

Grid			
Export to Grid	-2114 W	49.96 Hz	
L-V	230.1 Vac		
CT	0 W		
L-P	-2114 W		
Import From Grid	Today	0.0 kWh	Total 0.0 kWh
Export To Grid	Today	4.1 kWh	Total 12.2 kWh

By clicking on the Grid icon, you can access the grid details screen. In this screen, you can see the current status of the grid (Stand-by, Import From Grid and Export To Grid), which includes power and frequency.
L-V: Grid voltage.
CT: External current sensor grid power.
L-P: Internal current sensor grid power.
Import From Grid: Today and total grid

output power.

Export To Grid: Grid power sold today and in total.

Battery Detail Page

Battery	
Battery Status	Discharge
SOC	100 %
Voltage	48.90 Vdc
Current	1.9 Adc
Power	94 W
Temperature	27.9 °C

The image on the left shows the display screen when using % to measure the remaining power of the battery and make settings.

Battery	
Battery Status	Discharge
Voltage	48.90 Vdc
Current	1.9 Adc
Power	94 W
Temperature	27.9 °C

The image on the left shows the display screen when using voltage to measure the remaining power of the battery and make settings.

Li-BMS	
Battery Status	Discharge
SOC	43 %
Voltage	52.7 Vdc
Current	5.2 Adc
Power	274 W
Temperature	28.4 °C

If you use Lithium Battery, you can enter 1-2 page.

Li-BMS			
Mean Voltage	52.8 Vdc	Charging Voltage	56.8 Vdc
Total Current	1.5 Adc	Discharging Voltage	46.8 Vdc
Mean Temp	28.4 °C	Charging Current	100.0 Adc
Total SOC	43 %	Discharging Current	100.0 Adc
Dump Energy	45 Ah		

Inverter Detail Page

Inverter		
Power	225 W	50.00 Hz
L-V	230.1 Vac	
L-I	9.3 Aac	
L-P	225 W	
AC-Temp	38.9 °C	
DC-Temp	38.9 °C	

Inverter Generation Power and Frequency.
Voltage, Current, Power for each phase.
AC-Tem: Temperature of Heat-sink.
DC-Temp: Temperature of DC-DC module.

Generator Detail Page

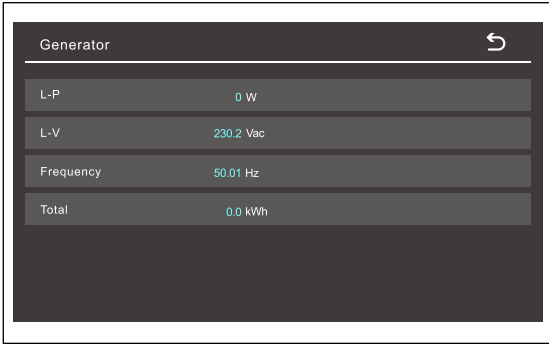

Generator Power, Voltage and Frequency.
Generator exportation for Total.

Load Detail Page

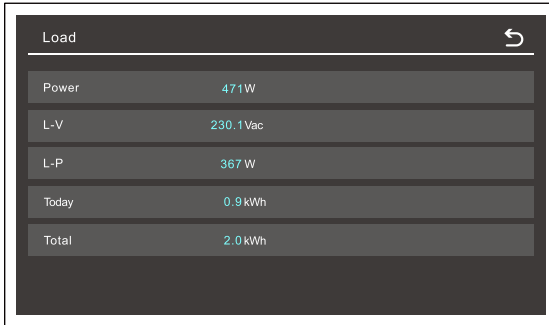

In this screen, you can see the voltage, power, daily consumption and total consumption of the load.

7.3 Setting Menu

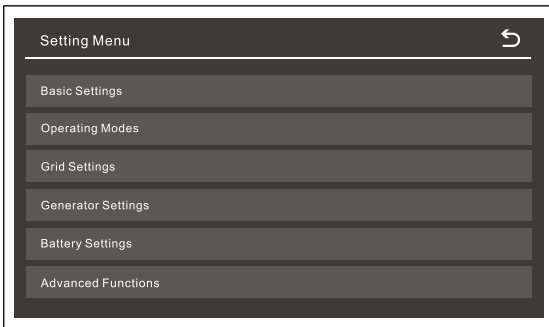

This is Setting menu detail page.

7.4 Basic Settings

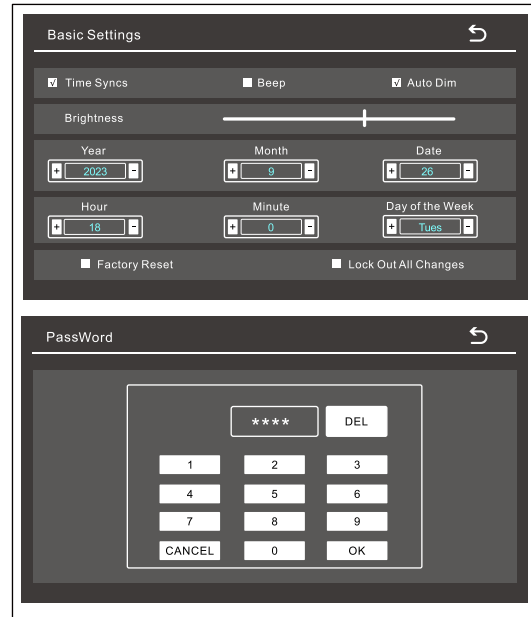

Factory Reset: Reset all parameters of the Inverter.

Lock Out All Changes: Enable this menu for setting parameters that require locking and can not be set up. Before performing a successful factory reset and locking the systems, to keep all changes you need to type in a password to enable the setting.

The password for factory settings is 9999.

7.5 Battery Settings

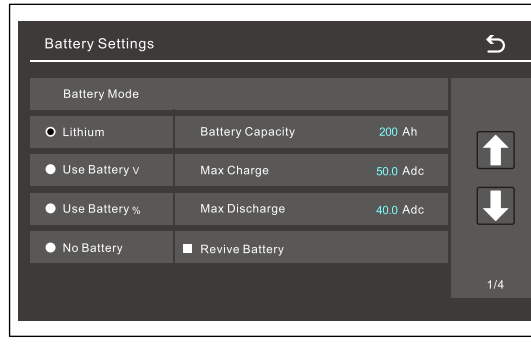

Lithium: Choose Lithium for Battery Mode if lithium battery is used.

Battery Capacity: Enter the size of the battery bank connected to the system.

Use Battery V: When using lead-acid battery, choose Use Battery V if you want to use voltage as the unit of actual battery capacity and do the setup.

Use Battery %: When using lead-acid

battery, choose Use Battery %, if you want to use percentage as the unit of actual battery capacity and do the setup.

Max Charge/Discharge: Set the max charge/discharge rate for the batteries.

No Battery: Tick this item if no battery is connected to the system.

Revive Battery: If lithium battery is used but the inverter and the battery are incompatible in communication, please enable the Revive Battery function to wake up the battery. If the lithium battery is compatible with the inverter in communication, then the inverter is able to wake the lithium battery when PV or grid is connected whether the Revive Battery function is enabled or not.

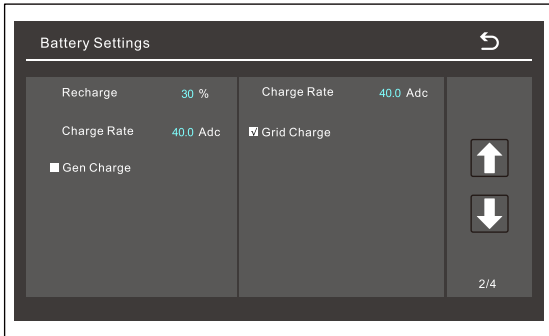

Recharge (Left) : When there is a blackout and Automatic Start for generator is enabled the generator will automatically start and charge the battery if the actual battery capacity is lower than the Recharge value.

Charge Rate = 40Adc: The maximum generator charging current.

Charge Rate(Left): Current of generator charging the battery.

Gen Charge: Enable this to allow generator to charge the battery.

Charge Rate (Right) : Current of grid charging the battery.

Charge Rate = 40Adc: The maximum grid charging current.

Grid Charge: Enable this to allow grid to charge the battery.

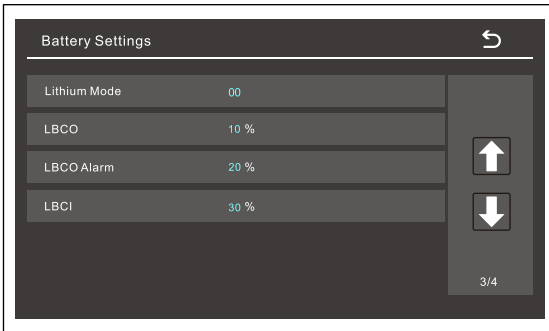

Lithium Mode: The communication protocol used between the inverter and lithium battery. Please set this according to the Appendix I at the end of user manual.

LBCO: Low Battery Cut Off. The default value is 10%. The minimum value that can be set is 5%. The set value must match $LBCO < LBCO \text{ alarm} < LBCI$, otherwise the setting will not be successful.

The inverter will shutoff its AC output if the actual battery capacity is lower than this value. The backup load can still be powered by the grid.

LBCO Alarm: Low Battery Cut Off Alarm, the inverter will send alarm if the actual battery value reaches this value. The default value is 20%. The minimum value can be set is 10%. The set value must match $LBCO < LBCO \text{ alarm} < LBCI$, otherwise the setting will not be successful.

LBCI: Low Battery Cut In. The inverter AC output will resume if actual battery capacity reaches this value. The default value is 30%. The minimum value can be set is 29%. The set value must match $LBCO < LBCO \text{ alarm} < LBCI$, otherwise the setting will not be successful.

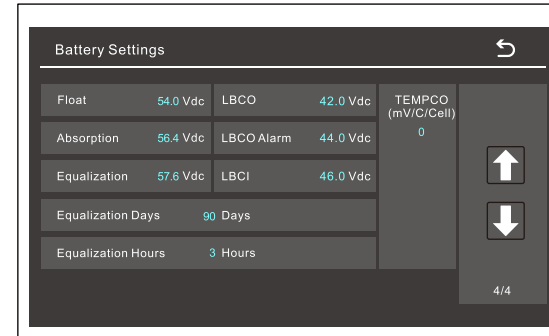

Float, Absorption, Equalization are three stages of charging the battery.

LBCO 42Vdc: The inverter will shutdown if the voltage below this value.

LBCO Alarm 44Vdc: The inverter will alarm if the voltage below this value.

LBCI 46Vdc: After the battery low voltage alarm, the alarm information above 46V is cleared.

This is for professional installers, you can keep it if you do not know.

Recommended battery settings:

Battery Type	Absorption	Float	Equalization
AGM(or PCC)	14.4V(57.6V)	13.5V(53.6V)	14.4(57.6V)
Gel	14.1V(56.4V)	13.5V(54.0V)	
Wet	14.7V(59.0V)	13.7V(55.0V)	14.7(59.0V)
Lithium	Follow its BMS voltage parameters		

7.6 Operating Modes

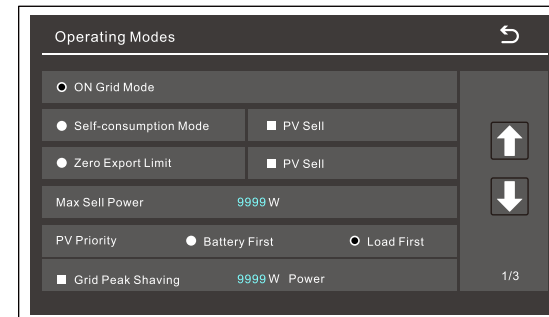

On Grid Mode: The inverter will sell any excess power produced by the solar panels back to the grid. If you enables the "time of use" function, the battery energy can also be sold into grid.

The PV energy will be used to power the load and charge the battery and then excess energy will flow to grid.

Power source priority for the load is as follows:

- 1.Solar Panels.
- 2.Grid.
- 3.Battery.

General description:

- a. The inverter will measure all power from the "GRID" terminal as sell power.
- b. External CT sensor not required for this system work mode.

c. Enable "ON Grid Mode" function and set the "Max Sell Power" (KW).

(How to install CT and set CT, please refer to 3.6 and 7.9).

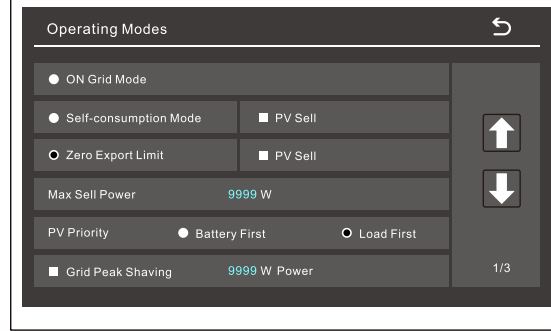
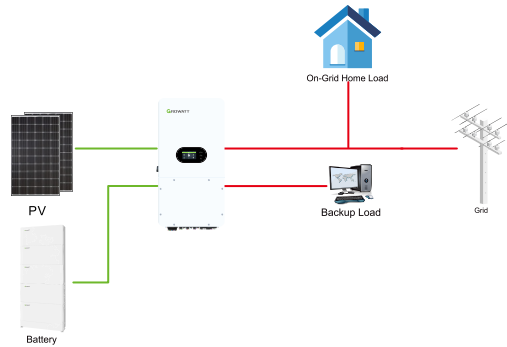

Zero Export Limit: Hybrid inverter will not only provide power to the backup load connected but also provide to the home load connected. If PV power is insufficient, it will take grid energy as supplement unless TOU or grid peak shaving is set. The hybrid inverter will not sell power to grid. In this mode, a meter is needed. The installation method of the meter please refer to chapter

2.6 CT Connection, The external meter will detect power flowing back to the grid and will reduce the power of the inverter only to supply the local load, charge battery and home load. Enable "PV Sell" it can sell electricity to the power grid.

General description not select "PV Sell":

- a. Power is delivered to the whole home without selling the excess solar back to the grid.
- b. External CT sensor required for this system work mode. (How to install CT and set CT, please refer to 3.6 and 7.9)
- c. Enable "Grid Peak-Shaving" and set "Peak-shaving power(KW)" which is used to set the maximum power that the inverter will draw from its grid power.

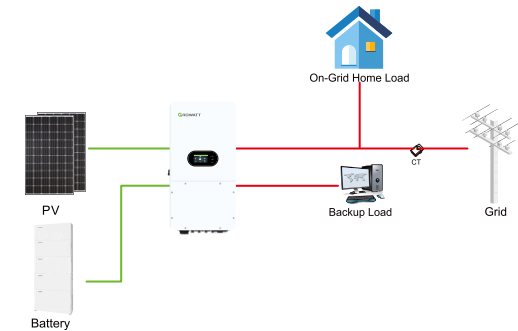

PV Sell: "PV sell" is for Self-consumption Mode or Zero Export Limit Mode: When this item is selected, the surplus energy can be sold back to grid. PV Power source priority usage is as follows: load consumption and charge battery and feed into grid.

Max Sell Power: Allowed the maximum output power to flow to grid.

PV Priority: PV Power source priority.

Battery First: PV power is firstly used to charge the battery and then used to power the load. If PV power is insufficient, grid will make supplement for battery and load simultaneously.

Load First: PV power is firstly used to power the load and then used to charge the battery. If PV power is insufficient, grid will make supplement for battery and load simultaneously.

Grid Peak Shaving: when it is selected, grid output power will be limited within the set value. If the load power exceeds the allowed value, it will take PV energy and battery as supplement, If still can't meet the load requirement, grid power will increase to meet the load needs. Under this working condition, only "Load First" can be selected. (This function can only take effect in Zero Export Limit mode). The minimum setting value is 1000W.

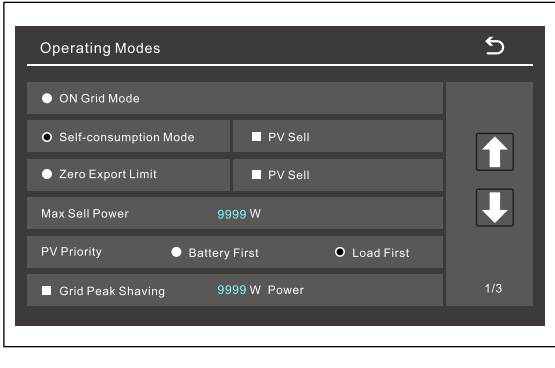

Self-consumption Mode: Hybrid inverter will only provide power to the backup load connected. The hybrid inverter will neither provide power to the home load nor sell power to grid. The built-in meter will detect power flowing back to the grid and will reduce the power of the inverter only to supply the local load and charge the battery. Enable "PV Sell", it can sell electricity to

the power grid.

General description not select "PV Sell":

- a. The inverter will only cover the loads connected to the "Backup LOAD" terminal.
- b. This work mode will not provide power to the "GRID" terminal.
- c. This system work mode is recommended for off-grid applications.

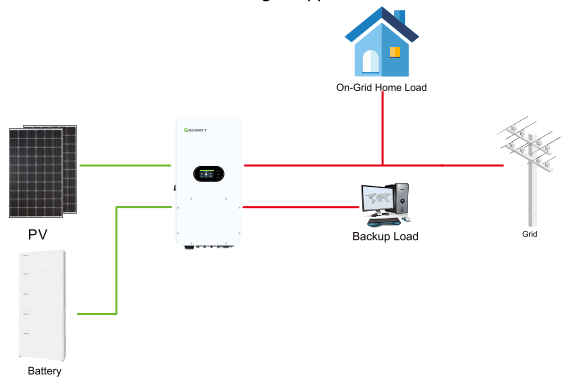

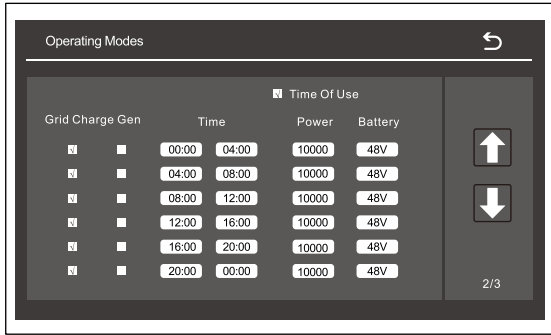

Time Of Use: It is used to program when to use grid or generator to charge the battery, and when to discharge the battery to power the load. Only tick "Time Of Use" then the follow items (Grid Charge, Gen Time, Power, Battery) will take effect. Using this mode, the inverter is allowed to discharge the battery to the grid or charge it to the battery within a specific time frame.

General description:

a. During the setting hours the system will discharge the batteries to deliver power or charge the batteries from the external AC power. All time intervals are automatically enabled.

b. Enable "Time of Use" function and set the Forced discharge time to discharge the batteries to deliver power.

Note: when in ON Grid Mode and click time of use, the battery power can be sold into grid.

Grid Charge: Utilize grid to charge the battery in a time period.

Gen: Utilize diesel generator to charge the battery in a time period.

Time: The time displayed on the inverter, range of 00:00-23:59.

Power: Max discharge power of battery allowed.

Battery(Vor SOC %): Battery SOC % or voltage at when the action is to happen. The default setting range is 44 to 54V or 36% to 100%. This setting needs to be greater than the LBCO alarm int the battery settings.

Gen: The generator does not currently support Time Of Use.

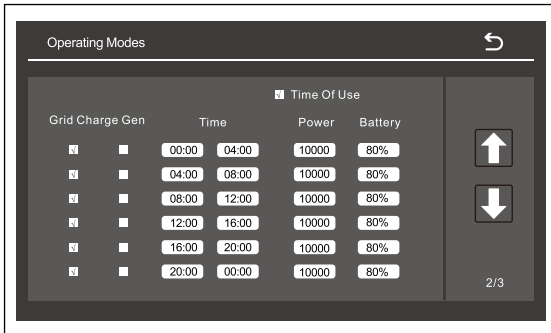

For example:

During 09:00-18:00, when battery SOC is lower than 80% it will use grid to charge the battery until battery SOC reaches 80%.

During 18:00-09:00,when battery SOC is higher than 80%,hybrid inverter will discharge the battery until the SOC

reaches 80%.

Battery: The default setting range is 36% to 100%.

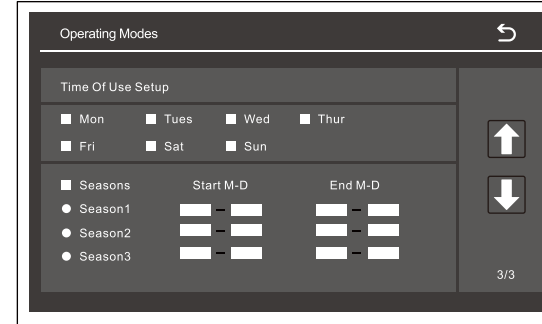

Week setting: The TOU function will only take effect after selecting the week.

Seasons: Enable Button(After selecting this option, Season1,2,3 will only take effect).

Season1,2,3: Automatically select based on the current time period.

Start M-D: Time on.

End M-D: End Time.

7.7 Grid Settings

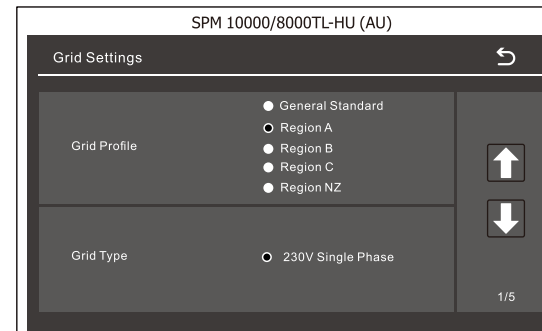

The password for entering this pages is 12 34.

Grid Mode: Please follow the local grid code and then choose the corresponding grid standard.

Grid Type: Set the Grid Type.

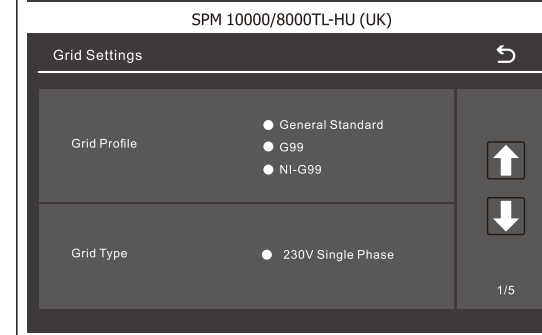
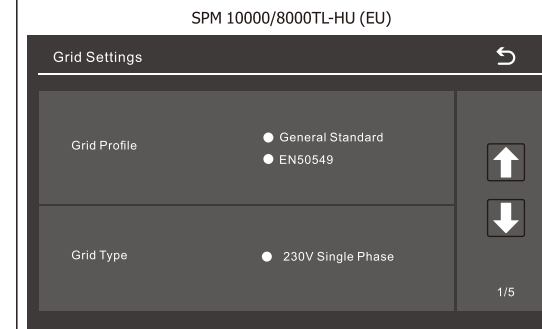

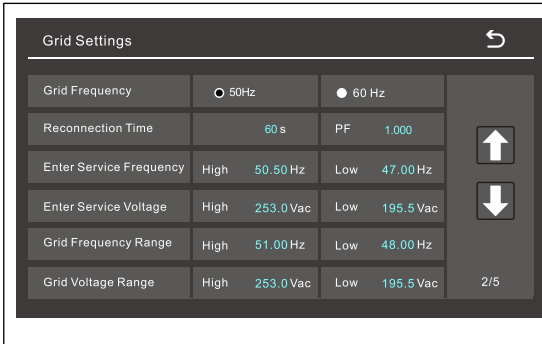

Grid Frequency: Set the grid frequency.
Reconnection time: The waiting time period for the inverter to connect the grid again.
PF: This is used to adjust the inverter's reactive power.
Enter Service Frequency/Voltage: Grid-connected voltage frequency range.
Grid Frequency/Voltage Range: Grid voltage frequency protection range.

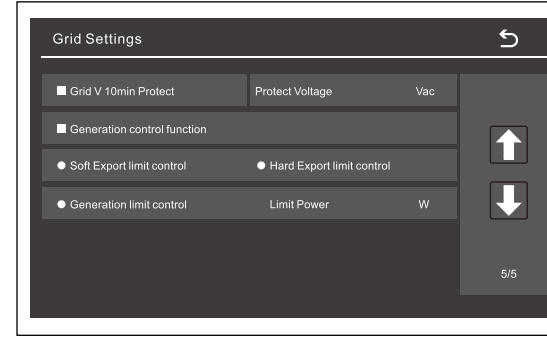

Grid V 10min Protect: When the average voltage of the mains power exceeds the set protection value for 10 minutes, the inverter will be disconnected from the grid for protection. This feature is available only in the Australian and European versions.
Soft Export limit control: When the soft limit is exceeded, the apparent power of the inverter will decrease to less than the soft limit within 15 seconds. This feature is available only in Australia

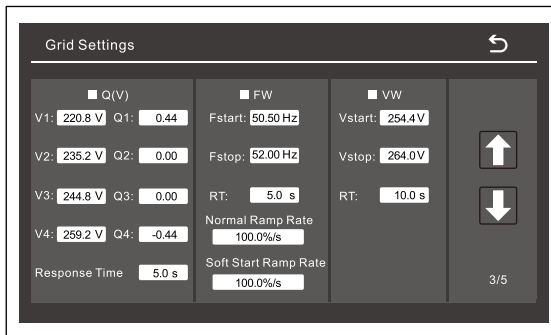

Q (V): It adjusts the inverter reactive power according to the set grid voltage. This function adjusts inverter output (active and reactive) power when grid voltage changes.
FW: This series inverter is able to adjust inverter output power according to grid frequency.

VW: It adjusts the inverter active power according to the set grid voltage.

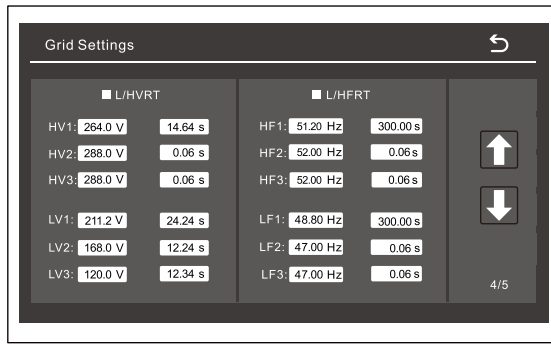

HV1: Level 1 overvoltage protection point.
HV2: Level 2 overvoltage protection point.
HV3: Untapped.
LV1: Level 1 undervoltage protection point.
LV2: Level 2 undervoltage protection point.
LV3: Untapped.
HF1: Level 1 over frequency protection point.
HF2: Level 2 over frequency protection point.

HF3: Untapped.

LF1: Level 1 under frequency protection point.

LF2: Level 2 under frequency protection point.

LF3: Untapped.

14.64s: Trip time.

Hard Export limit control: If the soft limit does not limit the mains power to below the limit value within 15 seconds, the hard limit will provide offline protection within 5 seconds. This feature is available only in Australia.
Generation limit control: Set power limits according to the city power supply, use an electricity meter to detect the mains power and adjust the selling power of the inverter within 15 seconds. This feature is available only in Australia.

7.8 Generator Settings

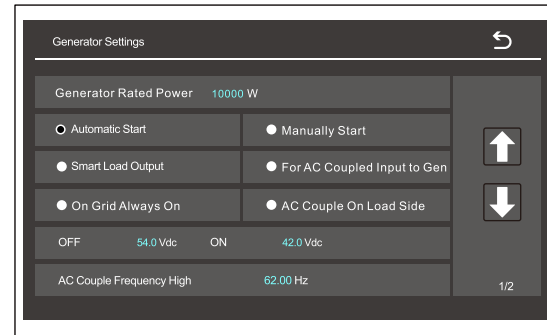

Generator Rated Power: Allowed Max. power from diesel generator.

Smart Load: Allows the generator to terminate the load.

For AC Coupled Input to Gen: connect the grid to the generator input port.

AC Couple On Load Side: To be developed.

On Grid Always On: When click "on Grid

always on" the smart load will switch on when the grid is present.

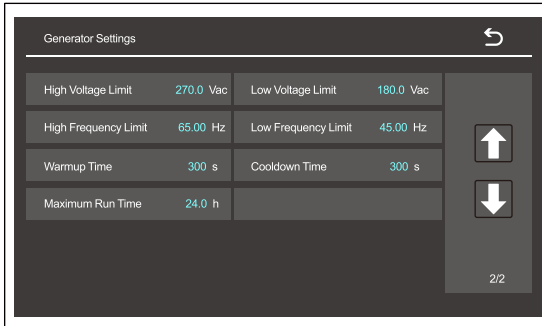

High/Low Voltage Limit:

Generator-connected voltage range.

High/Low Frequency Limit:

Generator-connected frequency range.

Warmup Time: After startup, the amount of time the generator runs (no-load) before the inverter is connected to the generator.

Cooldown Time: The amount of time the generator runs (no load) after the shutdown command is issued before the generator is actually shut down.

Maximum Run Time: When automatically started, the cumulative time allowed for continuous operation of the generator within 24 hours. The generator can be operated manually for any length of time.

7.9 Advanced Functions

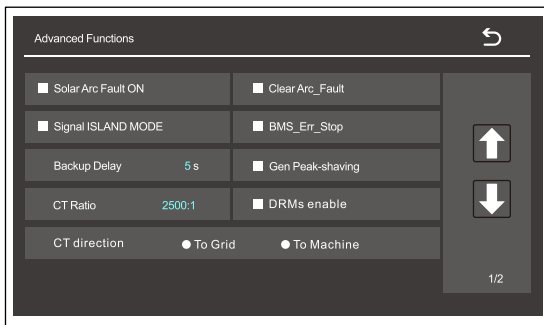

The password for entering this pages is 7777.

Solar Arc Fault ON: This is AFCI function.

Gen Peak-shaving: Enable When the power of the generator exceeds the rated value of it, the inverter will provide the redundant part to ensure that the generator will not overload.

BMS_Err_Stop: When the Battery Mode is Lithium,

- a) enable this function, the inverter will disconnect its output and send BMS error if the battery communication is abnormal. The output will be resumed after the communication is restored.
- b) disable this function, the Battery Mode will be changed to Use Batt V if the battery communication is abnormal, and the battery can only be discharged, not be charged.

Signal ISLAND MODE: when the inverter connects grid, the ATS port will output 240Vac and it is used to cuts off Earth-Neutral(load port N line) bond via connect external relay. When the inverter disconnects from the grid, ATS port voltage will be 0 and the Earth-Neutral bond keeps on, More details, please refer to above picture.

Clear Arc Fault: Clear AFCI error messages.

Backup Delay: To be developed.

Gen Peak-shaving: To be developed.

CT Ratio: The inverter support 4 ratios of CT clamp-1500:1, 2000:1, 2500:1 and 3000:1 . The CT Ratio of the CTs in the accessory bag is 2500:1.

CT direction: Selection of CT direction.

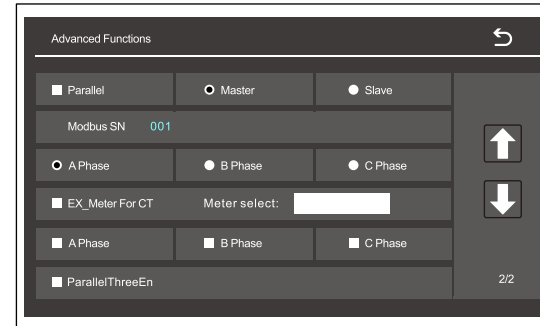

Parallel: This is the inverter's parallel function interface setting.

Ex_Meter For CT: This is the CT setting for the inverter, please leave it unchecked.

ParallelThreeEn: Three Phase enable.

Modbus SN: To be developed.

Meter Select: Selection of electric meter.

7.10 Device Info.

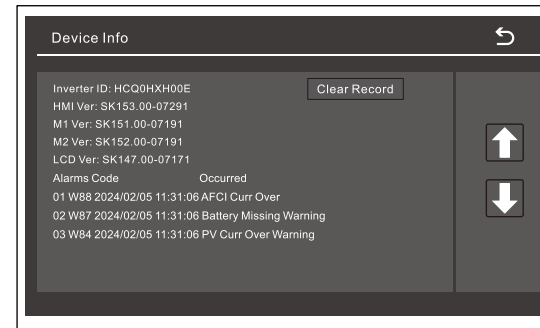

Inverter ID:This is the ID of the inverter.

HMI/M1/M2 Ver:This is the software version number of the inverter.

LCD Ver: LCD Verssion.

Clear Record: Clear error alarm messages.

8 Error Information and Processing

Error codes are divided into Warning codes and fault codes.

Warning codes identify the current statuses of the inverter(Max),it does not affect the normal running of the inverter.

When a numeric warning appears on the Main Screen , it can usually be cleared through orderly shutdown/re-set or self-corrective action performed by the inverter.Fault codes identify the possible equipment failure . incorrect setting or configuration of the inverter, all attempts to clear the fault code must be performed by qualified personnel.

Typically, error codes can be cleared . Some of error code as table shows below.

Auditing routine	Error Code	Description	Solutions
About PV	W81	PV Energy Low Warning	1.Check whether the PV voltage is too low. 2.If alarm message still exists, contact manufacturer.
	W83	PV Volt Over Warning	1.Check whether the PV voltage is greater than 550V. 2.If alarm message still exists, contact manufacturer.
	W84	PV Curr Over Warning	If there is an alarm message, please contact the manufacturer.
	W89	PV Over Load	1.Check whether the single-channel PV1 or PV2 power exceeds 8kW. 2.Check whether the single-channel PV3 power exceeds 15kW. 3.If alarm message still exists, contact manufacturer
	F33	PV Current Over	1.Check the connection between the PV module and the battery module. 2.Reduce the number of load connections in off-grid mode. 3.If the fault persists, contact the manufacturer.
	F39	PV BOOST Self Check Fault	1.Restart the inverter. 2.If the fault persists, contact the manufacturer.
	F40	PV Voltage Over	1.Check whether the actual PV voltage is consistent with the Main Screen. 2.Check whether the PV string voltage (Voc) is higher than the maximum input voltage of the inverter. If yes, adjust the number of PV modules in series to reduce the PV series voltage. 3.If the fault persists, contact the manufacturer.
	F56	PV ISO Fault	1.Check whether the connection between the PV module and the inverter is firm and correct. 2.Check whether the PE cable of the inverter is grounded. 3.If the fault persists, contact the manufacturer.
	Abut Grid . Generator	W68	Grid Relay Warning
W71		Gen Overload warning	1.Check whether the generator power exceeds 9kW. 2.If alarm message still exists, contact manufacturer.
F17		Grid Angle Fault	1.check grid type and frequency. 2.Restart the inverter. 3.If the fault persists, contact the manufacturer.
F26		Grid Type Fault	1.Restart the inverter. 2.If the fault persists, contact the manufacturer.
F28		Gen Overload Fault	1.Check whether the generator power exceeds 9kW. 2.If the fault persists, contact the manufacturer.

About inverter	W01	Fan lock warning	1.Check fan wiring after shutdown. 2.If alarm message still exists, contact manufacturer.
	W02	Meter Connect warning	1.Check meter wiring after shutdown. 2.If alarm message still exists, contact manufacturer.
	W03	LCD Connect warning	1.Check LCD wiring after shutdown. 2.If alarm message still exists, contact manufacturer.
	W04	USB Connect warning	1.Check USB wiring after shutdown. 2.If alarm message still exists, contact manufacturer.
	W10	RSD Stop Press Alarm	1.Check if the emergency stop button is pressed. 2.If alarm message still exists, contact manufacturer.
	W11	M3 Update Alarm	1.Check if the machine is in the process of upgrading. 2.If alarm message still exists, contact manufacturer.
	W12	MDSP update Alarm	
	W13	SDSP update Alarm	
	W67	Inverter Relay Warning	1.Restart the inverter. 2.If alarm message still exists, contact manufacturer.
	W70	GFCI Warning	1.Please charge for 10 minutes before inverter. 2.If alarm message still exists, contact manufacturer.
	W73	MDSP-METER Connect warning	1.Check meter wiring after shutdown. 2.If alarm message still exists, contact manufacturer.
	W80	CT Warning	1.Please check the wiring of the current transformer. 2.If alarm message still exists, contact manufacturer.
	W85	Mos Temperature Over	If there is an alarm message, please contact the manufacturer.
	W86	Transfer Temperature Over	If there is an alarm message, please contact the manufacturer.
	W88	AFCI Curr Over Warning	1.Shut down and check for poor contact or tearing of PV component wires. 2.If the fault persists, contact the manufacturer.
	W90	Insulation Low	1.After shutdown, check if the panel shell is reliably grounded. 2.If alarm message still exists, contact manufacturer.
	W91	AFCI Communication fail	1.After shutdown, check if the AFCI line inside the machine has fallen off. 2.If the fault still exists, please contact us for help.
	W92	AFCI self test fail	1.Restart inverter. 2.If the fault persists, contact the manufacturer.
	F18	Inverter Over Curr Fault	1.Check if the load is within the power range. 2.Restart the inverter. 3.If the fault persists, contact the manufacturer.
	F19	MSDSP Connect Fault	1.Restart the inverter. 2.If the fault persists, contact the manufacturer.
F24	Inverter Voltage Fault	1.Test if the actual output inverter voltage is consistent. 2.Restart the inverter. 3.If the fault persists, contact the manufacturer.	
F25	Relay Fault	1.Restart the inverter.	
F27	GFCI Fault	2.If the fault persists, contact the manufacturer.	
F34	Bus Volt Over	1.Restart the inverter 2-3 times. 2.If the fault persists, contact the manufacturer.	
F35	Bus Volt Unbalance		
F34	Bus Volt Over		

	F41	Heat Sink High Temperature Failure	1.Check that the inverter is not installed in a place where the sun shines, and ensure that the inverter is installed in a cool and ventilated place.
	F42	Transfer Temperature Over	2.Check whether the working temperature is too high, and make sure that the inverter is installed vertically. 3.Turn off the inverter for 10 minutes, then restart the inverter. 4.If the fault persists, contact the manufacturer.
	F44	AFCI Check warning	1.Restart the inverter.
	F45	BUS Start Error	2.If the fault persists, contact the manufacturer.
	F49	M3_MDSP Connect Fault	1.Shut down and check whether the communication line is firmly connected. 2.Restart the inverter. 3.If the fault persists, contact the manufacturer.
	F52	RSD Check Fault	1.Restart the inverter.
	F53	Version Different	2.If the fault persists, contact the manufacturer.
	About Load	W65	Output Short Warning
W66		Output Overload Warning	1.Check whether the output is short-circuited. 2.Shut down and restart to check whether the machine can work normally. 3.If alarm message still exists, contact manufacturer.
F20		DC Weight High	1.Restart the inverter. 2.If the fault persists, contact the manufacturer.
F21		Output Short	1.Check if the load is short circuited. 2.Restart the inverter. 3.If the fault persists, contact the manufacturer.
F22		Output Over Load	1.Check if the load is within the power range. 2.Restart the inverter. 3.If the fault persists, contact the manufacturer.
F23		Output Over Curr	1.Restart the inverter. 2.If the fault persists, contact the manufacturer.
About Battery		W14	BMS Update Alarm
	W15	BMS alarm	If alarm message still exists, contact manufacturer.
	W16	BMS update parameter alarm	1.Please set the 'Lithium Mode' to 01 in the Battery Settings on the LCD, then proceed with the battery upgrade. 2.If alarm message still exists, contact manufacturer.
	W69	Bat Energy Warning	1.Please charge for 10 minutes before inverter. 2.If alarm message still exists, contact manufacturer.
	W82	Bat Volt Low Warning	1.Check if the battery voltage is too low. 2.If alarm message still exists, contact manufacturer.
	W87	Battery Loss Warning	1.There is no electric voltage at the input end of the machine battery. 2.After confirming that the battery voltage is normal, turn on the machine to check whether it can work normally. 3.If alarm message still exists, contact manufacturer.
	F36	Battery Voltage Over	1.Check whether the actual connected battery voltage is consistent with the display. 2.If the battery voltage is too low, use photovoltaic or

			commercial power to charge the battery. If the battery voltage is too high, please connect to a battery within the required range. 3.If the fault persists, contact the manufacturer.
	F37	Bat Charge Current Over	1.Check whether the actual battery current is consistent with the display.
	F38	Bat DisCharge Current Over	2.Restart the inverter. 3.If the fault persists, contact the manufacturer.
	F51	M3_BMS connect fault	1.Shut down and check whether the communication line is firmly connected. 2.Restart the invert. 3.If the fault persists, contact the manufacturer.
	F57	BMS Fault	1.Restart the inverter.
	F58	Battery Mode Fault	2.If the fault persists, contact the manufacturer.
	W05	Grid Different	1.After shutting down the inverter, check if the grid power supply cables are correctly connected. 2.If the warn persists, contact the manufacturer.
	W06	Grid Phase Error	1.After disconnecting the grid power supply from the inverter, check whether the grid connection phase sequence matches the parallel operation settings on the Main Screen. 2.Restart the inverter. 3.If the warn persists, contact the manufacturer.
About Parallel	W07	Op Phase Loss	1.Check if the parallel operation parameters settings on the inverter's LCD interface are correct. 2.Restart the inverter. 3.If error message still exists, contact manufacturer.
	W08	Parallel Version Different	If the warn still exists, please contact us for help.
	W09	Capacity Different	If the warn still exists, please contact us for help.
	F29	Parallel Setting Fault	1.Check if the master-slave settings in the parallel operation settings on the LCD interface of the inverter are correct . 2.Restart the inverter. 3.If error message still exists, contact manufacturer.
	F30	Parallel M-AC Phase Order	1.After disconnecting the grid power supply connected to the inverter, check whether the grid connection phase sequence matches the parallel operation settings. 2.Restart the inverter. 3.If error message still exists, contact manufacturer.
	F31	Parallel CN-AC Phase Order	1.Restart the inverter. 2.If error message still exists, contact manufacturer.
	F54	Can Fault	1.After shutting down the inverter, check if the parallel communication cables are securely and correctly connected. 2.Restart the inverter. 3.If error message still exists, contact manufacturer.
	F55	Host Loss	1.Restart the inverter. 2.If error message still exists, contact manufacturer.
	F59	Parallel BMS Connect Error	1.Connect the BMS communication cable to the 'Master Phase A' port of the inverter. 2.Restart the inverter. 3.If error message still exists, contact manufacturer.

9 Data Sheet

Model	SPM 10000TL-HU (AU)	SPM 10000TL-HU (EU)	SPM 10000TL-HU (UK)	SPM 8000TL-HU (AU)	SPM 8000TL-HU (EU)	SPM 8000TL-HU (UK)
PV Input Data						
Max Recommended PV Power	20000W	20000W	20000W	16000W	16000W	16000W
DC/AC Ratio	2					
PV Input Voltage(V)	370V(130V-550V)					
MPPT Range(V)	150V-500V					
Start-up Voltage(V)	130V					
PV Input Current(A)	16A+16A+32A			16A+16A+16A		
No. of MPPT Trackers	3					
No. of PV strings per MPP trackers	2/2/2					
Battery Data						
Battery Type	Lead-acid or Li-Ion					
Nominal Voltage(V)	48V					
Battery Voltage Range(V)	40-60V					
Max Charging Current(A)	200A		190A	165A		
Max Discharging Current(A)	200A		190A	165A		
Output/Input Data(On Grid)						
Rated Voltage	230Va.c. (single phase),					
Continuous Power Output/Input (W)	9999W	10000W		8000W		
Rated apparent power(VA)	9999VA	10000VA		8000VA		
Nominal Output/Input Current(A)	43.5A			34.8A		
Max. AC Current(A)	50A			40A		
Power Factor	0.8 leading to 0.8 lagging					
Output Frequency	50Hz					
Grid Type	Single phase					
THDI	<3%					

Backup Power(Off Grid)						
Rated Voltage	230Va.c. (single phase)					
AC Nominal Output Power(W)	9999W	10000W		8000W		
Rated apparent power(VA)	9999VA	10000VA		8000VA		
Peak Power(grid off)	1.5 times of rated power, 5 s					
AC Output Rated Current(A)	43.5A			34.8A		
Output Frequency	50Hz					
Switch Time	< 10ms					
Efficiency						
Max Efficiency	98.10%					
Euro Efficiency	97.60%					
MPPT Efficiency	99.90%					
Protection						
PV Switch	Yes					
BAT reverse protection	Yes					
Output over current protection	Yes					
AC short-circuit protection	Yes					
PV Input Lightning Protection	Yes					
Anti-islanding Protection	Yes					
PV String Input Reverse Polarity Protection	Yes					
Insulation Resistance Monitoring	Yes					
Residual Current Monitoring Unit	Yes					
Surge Protection	DC Type II / AC Type II					
Certifications and Standards						
Compliance	AS4777.1:2024, AS609473, CSIP-AUS EN IEC61000-6-2, EN IEC61000-6-4, EN62109-1, EN62109-2	EN50549-1/10, IEC62109-1, IEC62109-2, EN61000-6-1, EN61000-6-3	G99, NI-G99, IEC62109-1, IEC62109-2, EN61000-6-1, EN61000-6-3	AS4777.1:2024, AS609473, CSIP-AUS, EN IEC61000-6-2, EN IEC61000-6-4, EN62109-1, EN62109-2	EN50549-1/10, IEC62109-1, IEC62109-2, EN61000-6-1, EN61000-6-3	G99, NI-G99, IEC62109-1, IEC62109-2, EN61000-6-1, EN61000-6-3

General Data	
Operating Temperature Range(°C)	-25~60°C , >45°C Derating
Cooling	Smart cooling
Noise(dB)	<30 dB
Communication with BMS	RS485; CAN
Weight(kg)	42.5
Size(mm)	855H*440W*255.6D
Protection Level	IP65
Installation Style	Wall-mounted
Warranty	10 years

10 Appendix I

Approved battery brand from Growatt.

Brand	Model	RS485 or CAN	Inverter Setup
GROWATT	ALP 5.0L-E2-US	CAN	01
	AXE 5.0L-C1	CAN	01
	HOPE 5.5L-A1	RS485	00
		CAN	01

For other compatible batteries, please refer to the official website of Growatt.

11 Appendix II

Definition of RJ45 Port Pin for BMS.

NO.	BMS
1	RS485B
2	RS485A
3	/
4	CAN-H
5	CAN-L
6	GND
7	/
8	/

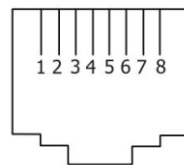

12 Appendix III

CT installation recommendation.

CT model	CT ratio	CT aperture	Property	Recommendation system
100A	2500:1	17mm	Standard configuration	single-phase system 3PCS three-phase parallel systems
200A	5000:1	37mm	Purchase from Growatt	2-3PCS single-phase parallel systems 6PCS three-phase parallel systems
500A	12500:1	37mm	Purchase from Growatt	4-6PCS single-phase parallel systems

13 Appendix IV

Meter installation recommendation

Meter type	Property	Recommendation system
TPM-CT-E-EU(250A CT)	Purchase from Growatt	3-6 PCS three-phase parallel systems
SPM-CT-E(100A)	Purchase from Growatt	Single-phase system
SPM-CT-E (200A)	Purchase from Growatt	2 PCS single-phase parallel systems
SPM-CT-E (500A)	Purchase from Growatt	3-6 PCS single-phase parallel systems

14 Appendix V

Certificates

With the appropriate settings, the unit will comply with the requirements specified in the following standards and directives (dated: Aug./2024):

Model	Certificates
SPM 8000-10000TL-HU (AU)	AS4777.1.2024,AS609473,CSIP-AUS,EN IEC61000-6-2 ,EN IEC61000-6-4, EN62109-1,EN62109-2
SPM 8000-10000TL-HU (EU)	EN50549-1/10,IEC62109-1,IEC62109-2,EN61000-6-1,EN61000-6-3
SPM 8000-10000TL-HU (UK)	G99,NI-G99,IEC62109-1,IEC62109-2,EN61000-6-1,EN61000-6-3