

APstorage Sea Family ELT Series PCS Installation & User Manual

(For EMEA)

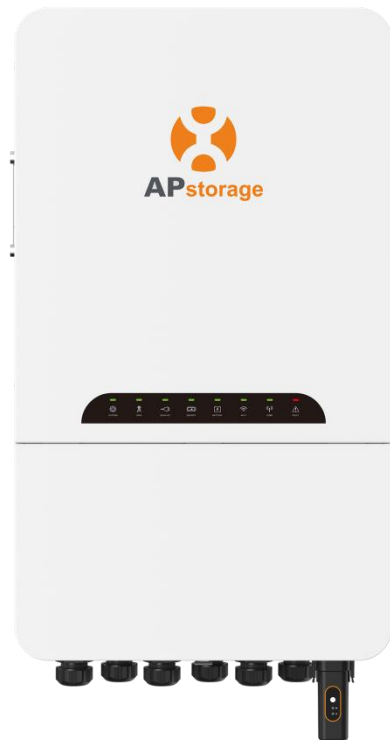

Table of Contents

1. Important Safety Instructions	1
1.1 Safety Instructions	1
1.2 Radio Interference Statement	1
1.3 Communication Disclaimer	1
1.4 Symbols in lieu of words	2
2. Product Introduction	3
2.1 Features	3
2.2 Basic System Architecture	4
2.3 Back-up Load Configuration	5
2.4 Casing Introduction	6
2.5 LED	7
3. Installation	8
3.1 Packing List	8
3.2 Select Mounting Location	8
3.3 PCS installed on the wall	9
3.4 Terminals and Cables Introduction	10
3.5 Electrical Wiring	11
3.6 Wiring System for PCS	14
3.7 Start PCS	16
3.7.1 Check all Below Steps Before Starting PCS	16
3.7.2 Power ON	16
3.7.3 Check the system	16
3.7.4 Power Off	16
4. Off-Grid AC Coupling Installation	17
4.1 Frequency Shift Power Control	17
4.2 PV System to APstorage Pairing	18
5. User Interface	19
6. Introduction to AI Mode	20
6.1 Standard Mode	20
6.2 AI Mode	20
7. Technical Data	21
EU DECLARATION OF CONFORMITY	22

1. Important Safety Instructions

This manual contains important instructions to be followed during installation and maintenance of the APstorage PCS. To reduce the risk of electrical shock and ensure the safe installation and operation of the APstorage PCS, the following symbols appear throughout this document to indicate dangerous conditions and important safety instructions.

DANGER:

This indicates a hazardous situation, which if not avoided, will result in death or serious injury.

WARNING:

This indicates a situation where failure to follow instructions may be a safety hazard or cause equipment malfunction. Use extreme caution and follow instructions carefully.

NOTE:

This indicates information that is very important for optimal system operation. Follow instructions closely.

1.1 Safety Instructions

IMPORTANT SAFETY INSTRUCTIONS. SAVE THESE INSTRUCTIONS. This guide contains important instructions that you must follow during installation and maintenance of the PCS. Failing to follow any of these instructions may void the warranty. Follow all of the instructions in this manual. These instructions are key to the installation and maintenance of the APstorage PCS. These instructions are not meant to be a complete explanation of how to design and install APstorage PCSs. All installations must comply with national and local electrical codes and standards.

DANGER:

- Only qualified professionals should install and/or replace the APstorage PCS.
- Perform all electrical installations in accordance with local codes.
- To reduce risk of burns, do not touch the body of the PCS.

WARNING:

- Do NOT attempt to repair the APstorage PCS. If it shows abnormal performance, Contact APsystems Customer Support to obtain adequate support. Damaging or opening the APstorage PCS will void the warranty.
- These servicing instructions are for use by qualified personnel only. To reduce the risk of electric shock, do not perform any servicing other than that specified in the operating instructions".

NOTE:

Before installing or using the APstorage PCS, please read all instructions and cautionary markings in the technical documents and on the APstorage PCS.

1.2 Radio Interference Statement

This equipment could radiate radio frequency energy which might cause interference to radio communications if you do not follow the instructions when installing and using the equipment. But there is no guarantee that interference will not occur in a particular installation. If this equipment causes interference to radio or television reception, the following measures might resolve the issues:

- A) Relocate the receiving antenna and keep it well away from the equipment.
- B) Consult the dealer or an experienced radio / TV technician for help.







Changes or modifications not expressly approved by the party responsible for compliance may void the user's authority to operate the equipment.

1.3 Communication Disclaimer

The EMA system provides a friendly interface to monitor the working status of the whole energy storage system. At the same time, it can also help to locate problems during system maintenance. If communication has been lost for more than 24 hours, please contact the technical support of APsystems.

1.4 Symbols in lieu of words

The following types of safety precautions and general information symbols used in this manual must be followed during the installation, operation and maintenance of the PCS.

	Caution, risk of electric shock.
	Caution, hot surface.
	NOTICE, danger! This device directly connected with electricity generators and public grid.
	After the inverter is turned off, wait for at least 5 minutes before opening the PCS or touching live parts.
	Refer to the operating instructions.
	Products shall not be disposed as household waste.
	CE mark.
Qualified personnel	Person adequately advised or supervised by an electrically skilled person to enable him or her to perceive risks and to avoid hazards which electricity can create. For the purpose of the safety information of this manual, a "qualified person" is someone who is familiar with requirements for safety, electrical system and EMC and is authorized to energize, ground, and tag equipment, systems, and circuits in accordance with established safety procedures. The inverter and storage system may only be commissioned and operated by qualified personnel.

2. Product Introduction

APStorage introduces its 1st generation of smart Power Conversion Systems with the ELT series products, the three-phase AC coupled Low Voltage battery inverter solution for residential PV applications.

With automatic energy management features based on intelligent software and integrated monitoring, system owners can choose between multiple energy control modes including back-up power supply, self-consumption, advanced and peak-shaving modes to secure critical loads during power outages, maximize energy savings and optimize electricity bills.

2.1 Features

Performance

- ▶ Nominal power rating up to 12000VA
- ▶ Peak backup power up to 18000VA
- ▶ Max efficiency up to 96.5%

Safety

- ▶ Ingress protection IP65
- ▶ 48V low battery voltage input
- ▶ Intelligent charging technology, protecting battery life
- ▶ High and low voltage isolation topologies, ensuring personal safety

Flexible

- ▶ Compatible with multiple battery brands
- ▶ Provide dedicated interface for connecting generator
- ▶ Support Off-grid PV function
- ▶ AC-Coupled solution for new or existing installations

Intelligent

- ▶ Support 100% three-phase unbalanced output
- ▶ UPS-level switching time <10ms
- ▶ Innovative multiple energy control modes: Backup power supply, Self-consumption, advanced and Peak shaving
- ▶ AI mode allows users to take advantage of dynamic electricity tariffs and optimize their savings
- ▶ 24-hour intelligent energy management system
- ▶ Intelligent operation and maintenance platform with EMA

2.2 Basic System Architecture

A typical APstorage system includes Two main elements:

- APstorage PCS, which is a smart battery Power Conversion System.
ELT Series PCS is a 3-phase Low Voltage Battery inverter for residential storage.
- A compatible Battery pack (see battery compatibility list)

Option 1 : PV system working off-grid

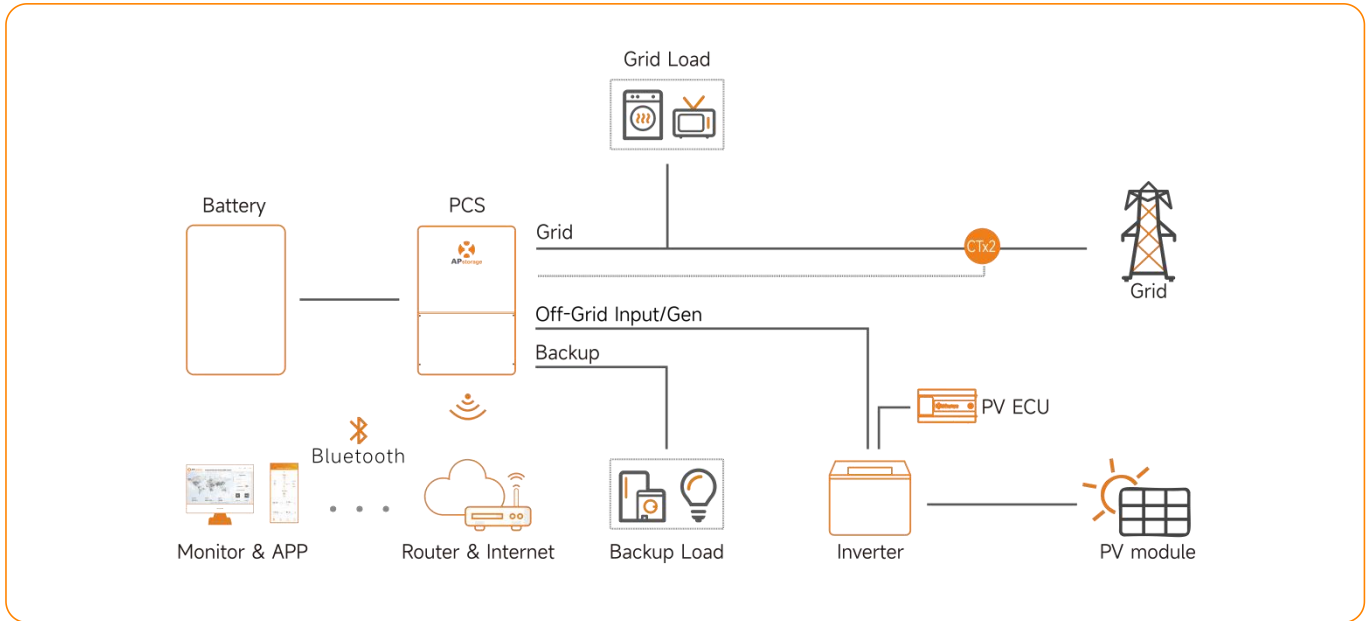

ELT-12 can control APsystems QT2/QT2D/DS3/DS3D Series inverters through frequency control, and it can also control other inverters through built-in relays.

Option 2 : PV system working grid

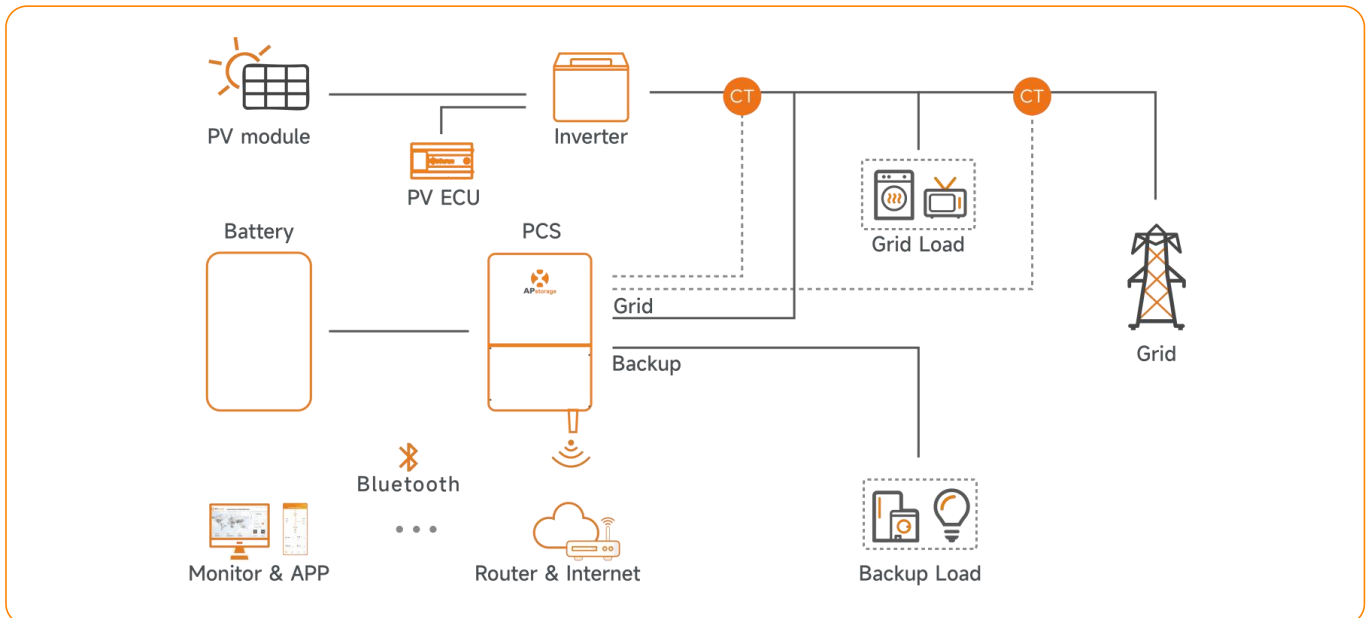

Option 3 : Mix of option 1 and 2 following the conditions above

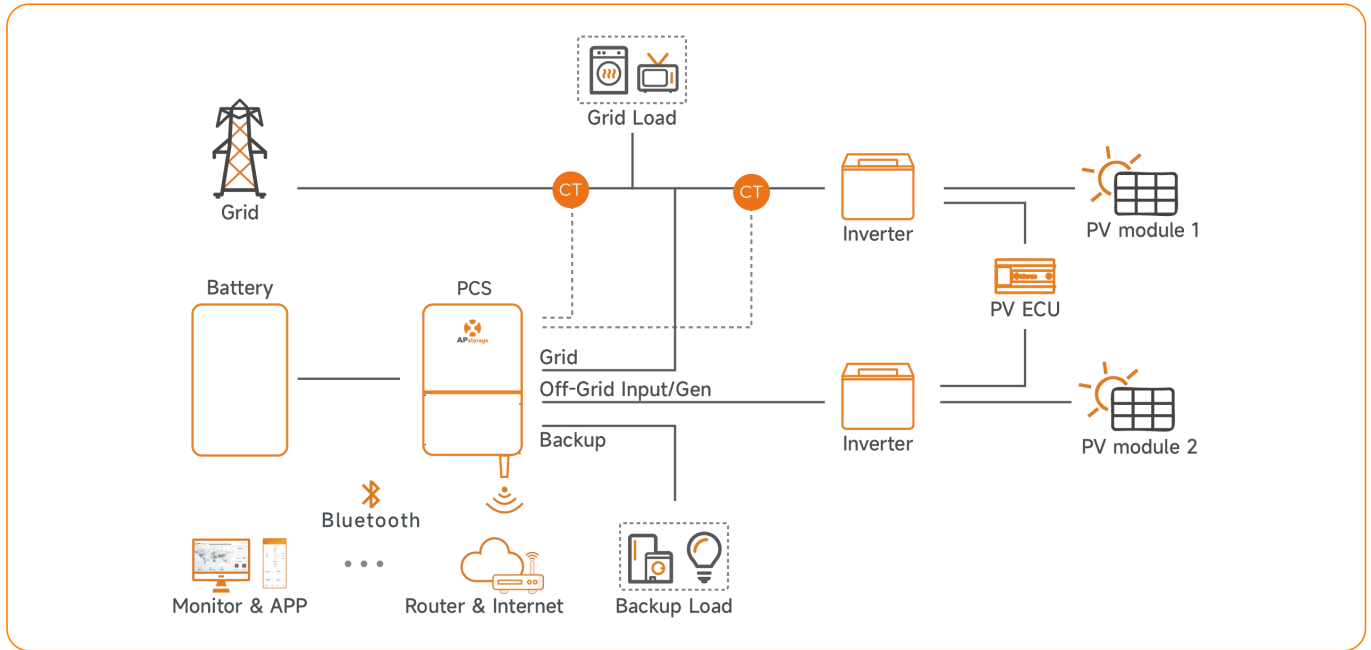

NOTE:

1. If the wireless signal in the area where the PCS is weak, it is necessary to add a Wi-Fi signal booster at a suitable place between the router and the PCS.
2. In a Storage System with APStorage PCS, the battery is one of the key components. Therefore, it is necessary to keep the installation environment well ventilated, please refer to Battery user manual.

2.3 Back-up Load Configuration

- Case1. If it is a three-phase load, then the total power of the three-phase load does not exceed 12kVA.
 Case2. If it is a single-phase load, the power of each phase load does not exceed 4kVA.

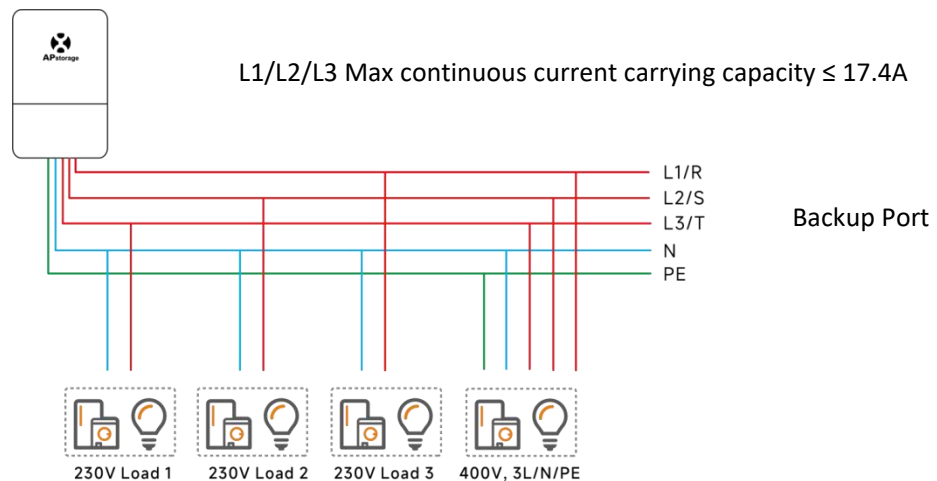

NOTE:

The specified single-phase load received by L1N, L2N, and L3N does not exceed 4kW. If there is a three-phase load, the power of the single-phase load needs to be subtracted and evenly distributed. For example, if the maximum single-phase load on L1N, L2N, and L3N is 2kVA each, then the maximum three-phase load is 6kVA.

- L1N: voltage between L1 and Neutral line**
- L2N: voltage between L2 and Neutral line**
- L3N: voltage between L3 and Neutral line**

2.4 Casing Introduction

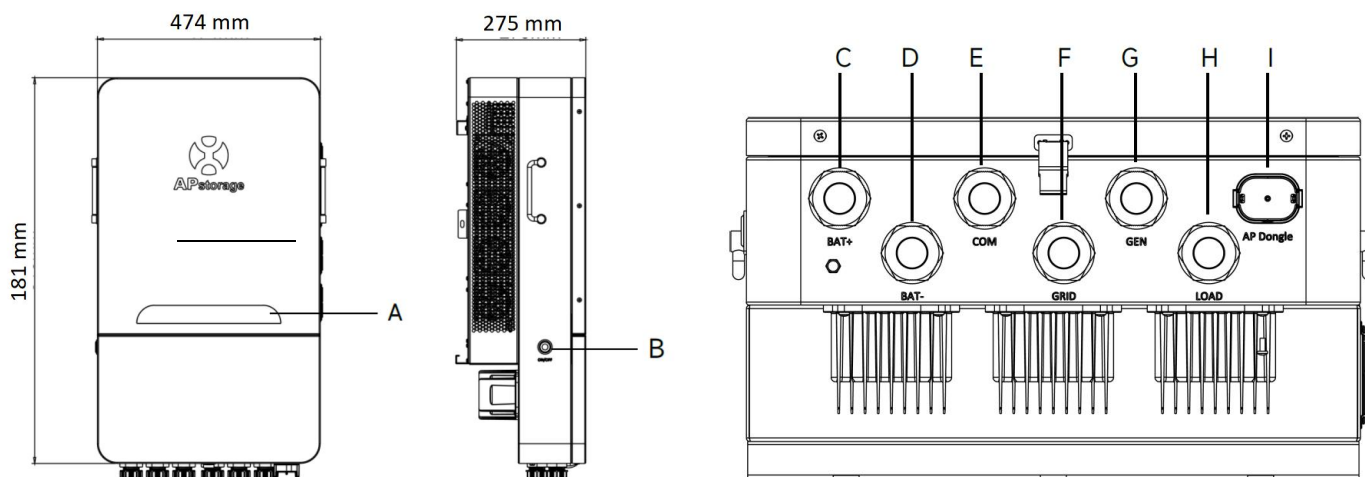

* The image shown here is for reference only. The actual product received may differ.

Object	Name	Description
A	LED	LED indicators
B	On/Off Button	Turn on/off the PCS
C	BAT+	Battery positive cable inlet
D	BAT-	Battery negative cable inlet
E	COM	Communication cables inlet
F	GRID	AC Grid cables inlet
G	GEN	Generator cables inlet
H	LOAD	Backup Load cables inlet
I	AP Dongle	AP Dongle insertion port

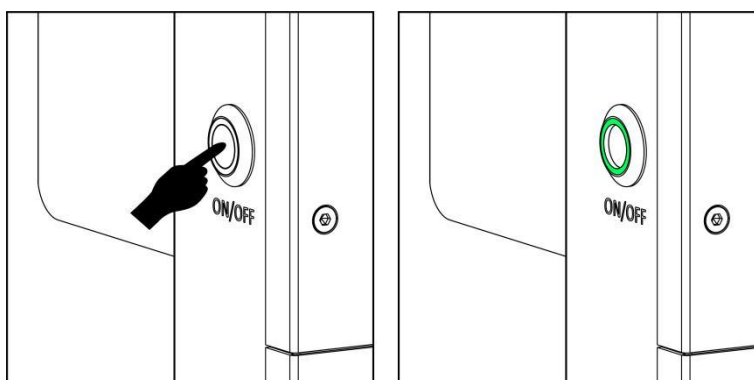

Once the PCS has been properly installed and the batteries are connected well, press On/Off button (located on the left side of the case) , wait 1 minute for the button's green light turns on indicating the PCS startup; press again to shut down.

2.5 LED

There are eight LED indicators on the PCS unit, indicating the working state of the PCS.



LED	Condition	Description
SYSTEM		The system is operating
		The system is starting up
		The system shutdown
GRID		The grid exists and is connected
		The grid exists but is not connected
		The grid does not exist
BACK UP		The backup system is operating
		The backup is off
ENERGY		Buy energy from grid
		Zero output
		Supplying energy to grid
		The grid is not connected or system is not operating
BATTERY		The battery is charging
		The battery is discharging
		The battery SOC is low
		The battery is disconnected
WI-FI		The WiFi is connected to the router
		The WiFi is not connected to the router
		The WiFi function is closed
COM		The battery and the internet communication are normal
		The battery communication is normal, but the internet communication is abnormal
		The battery communication is abnormal, but the internet communication is normal
		The battery and the internet communication are abnormal
FAULT		Fault has occurred
		Back up output overload
		No fault

: Light on

: Light off

: Every 5 seconds light on for 1 second.

: Every 2 seconds light on for 1 second.

3. Installation

3.1 Packing List

Check the equipment before installation. Please make sure nothing is damaged in the package. You should have received the items in the following package:

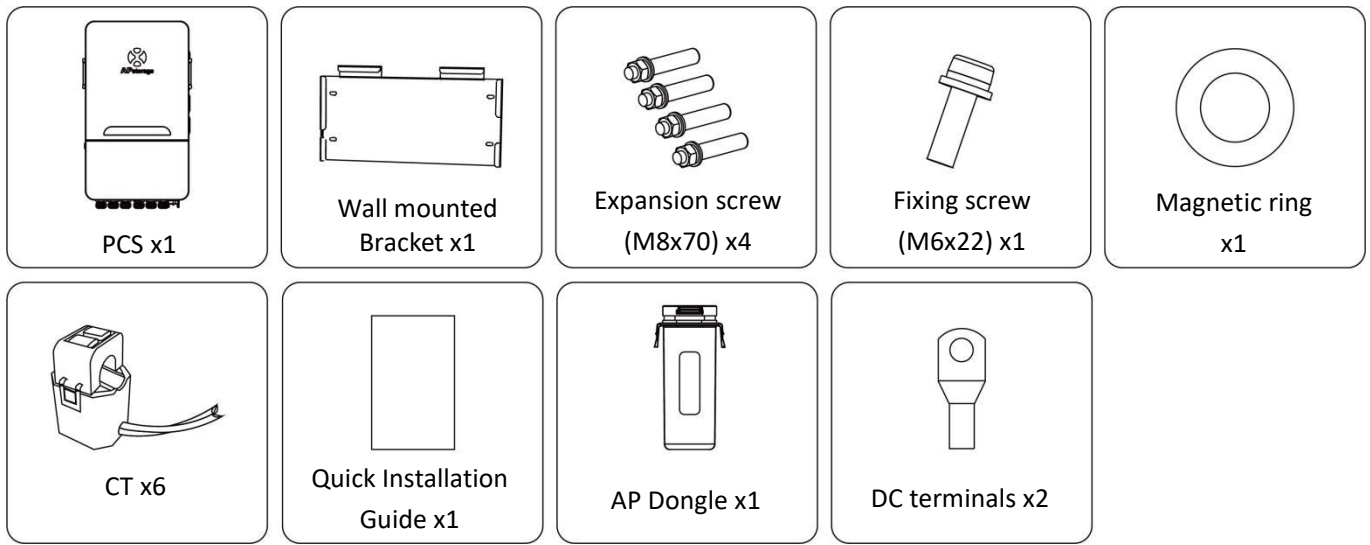

NOTES:

1. The expansion screws are applicable only to cement concrete walls. For other types of walls, install expansion screws based on the wall type.
2. The customer will need to purchase a combiner box for parallel connection of the batteries. Combiner box requirements: rated current of each connector $\geq 240A$.
3. If you need to connect a generator, you will need to purchase an additional generator-related function CT ring.

3.2 Select Mounting Location

1. PCS should be installed on a solid surface, where is suitable for PCS's dimensions and weight.
2. Do not install PCS in a confined space with no ventilation.
3. If the PCS is installed outside, it should be protected under shelter from direct sunlight or bad weather conditions (like snow, rain, lightning, etc). Fully shielded installation locations are preferred.

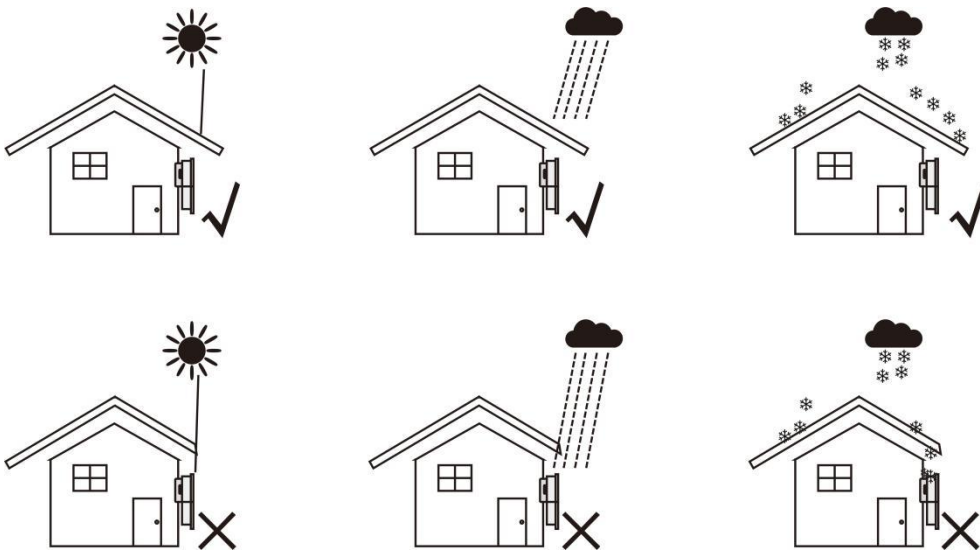

4. Install the PCS vertically on the wall.
5. Make sure that the PCS is mounted "face-up": Product logo is visible after installation.
6. Leave enough space around PCS. The specific requirements are as follows:

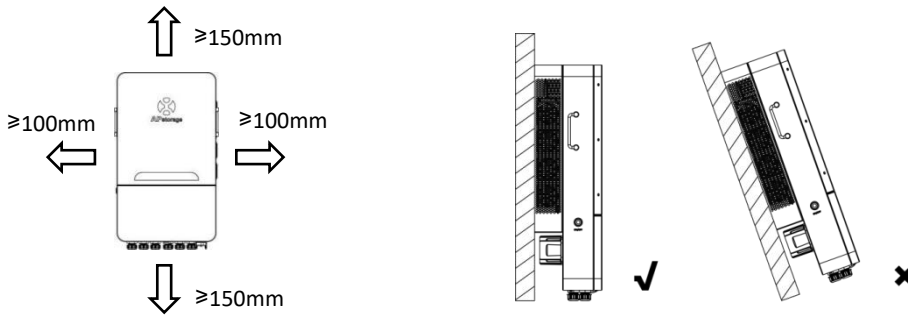

WARNING:

This indicates a situation where failure to follow instructions may be a safety hazard or cause equipment malfunction. Use extreme caution and follow instructions carefully.

3.3 PCS installed on the wall

STEP 1

Mark the holes position on the wall and drill holes according to wall type and expansion screws type. The configured expansion screw is drilled with a diameter of 12mm(0.5") and a depth of 50-55mm(1.9-2.2").

STEP 2

Put the expansion screws into the holes on the wall. Use a wrench to tighten the hex nuts, so that the expansion screws sleeve are fully expanded. Then remove the hex nuts. Hang the wall mounting bracket into the expansion screws, and use the hex nuts to fix it firmly. Make sure that the wall mounting bracket is horizontal after installation.

STEP 3

Lift the PCS to hang it into the wall mounting bracket, and fix the PCS on wall mounting bracket with the M6×22mm screw.



3.4 Terminals and Cables Introduction

When wiring, you need to crimp appropriate terminals on the cable (as shown for dimensions). The cables and terminals need to be prepared by yourself or purchased from APsystems.

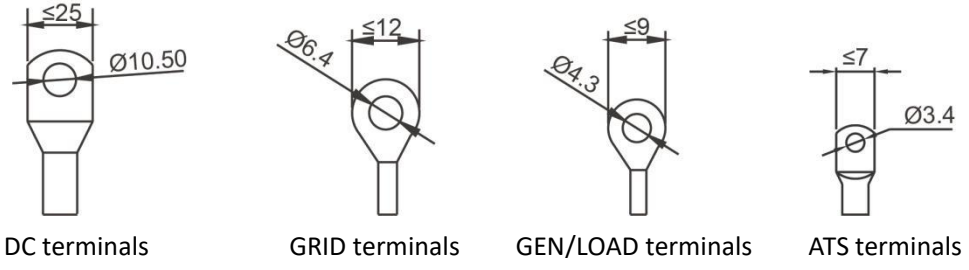

DC cable:

Model	Cable(mm ²)	Torque value
ELT-6	40	10Nm
ELT-8	40	10Nm
ELT-10	70	10Nm
ELT-12	70	10Nm

Grid cable:

Model	Cable(mm ²)	Torque value
ELT-6/8/10/12	6	2.5Nm

GEN/LOAD cable:

Model	Cable(mm ²)	Torque value
ELT-6/8/10/12	4	1.2Nm

ATS cable:

Model	Cable(mm ²)	Torque value
ELT-6/8/10/12	0.5	1.2Nm

Grid connection and backup load connection (Copper wires) (bypass) :

Model	Cable(mm ²)	Torque value
ELT-6/8/10/12	6	2.5Nm

PCS has been installed with cable glands before delivery. If connection is required through pipe (prepare pipe yourself), remove cable glands on the casing first. The pipe must be waterproof.

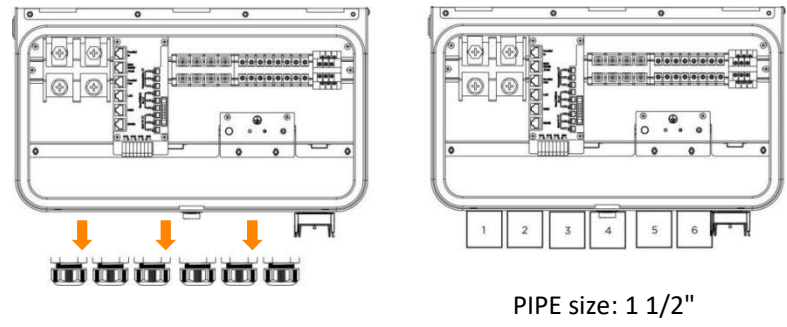

WARNING: Do not drill holes in the casing at any location, otherwise we will not provide warranty.

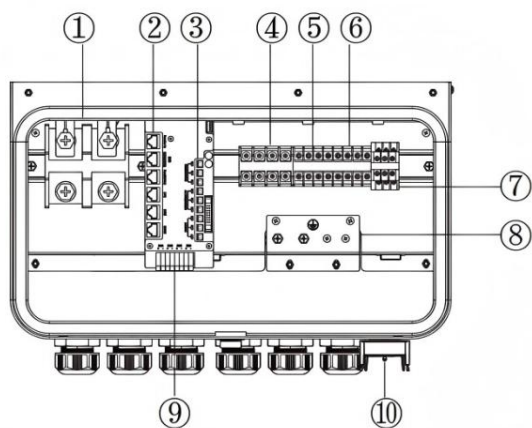

- ① BAT+ /BAT- Terminals
- ② Communication Terminals
- ③ CT Terminals
- ④ GRID Terminals
- ⑤ Off-Grid Input/Gen Terminals
- ⑥ LOAD Terminals
- ⑦ ATS Terminals
- ⑧ Ground Terminals
- ⑨ DO1/DO2/DO3 Terminals/RSD Terminals
- ⑩ AP Dongle

ATS Connection

N1 (Reserved, no wiring needed), N2 is the ATS external contactor interface (for use with generators), and N03 is the ATS external contactor interface (for use with off-grid PV). All interfaces must be connected to external contactors to enable functionality.

If you need to connect the generator side contactor, you can refer to the corresponding user manual.



DO Connection

The energy storage inverter PCS integrates multifunctional dry contacts (DO1, DO2, and DO3). The dry contacts can be set to one of the following functions: generator control and load control. The APstorage system supports third-party generators. In the event of a grid disconnection or other conditions, APstorage can automatically control the generator to start, serving as a backup power source for the battery and load.

RSD (Rapid Shutdown System): It can connect to an external switch for quickly shutting down the energy storage system, protecting the PCS.

For more information on the above two functions, please refer to the relevant user manual or contact the APstorage technical support team.

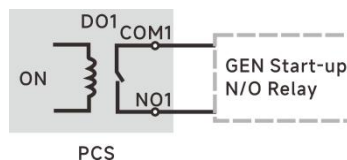
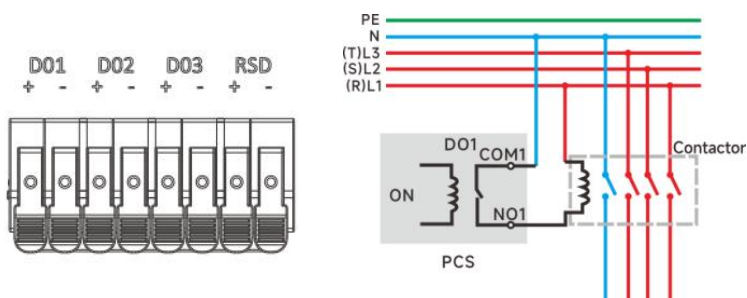

NOTE: Load control function reserved.

3.5 Electrical Wiring

STEP 1 Remove the bottom cover

Before connecting the wires, please unscrew the screws on the bottom cover, then open the buckle on the bottom cover, and remove the bottom cover.

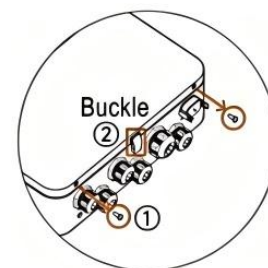

STEP 2 Battery Wiring

For battery wiring BAT+, please use red or orange cables, and for BAT -, please use black cables. As shown in the diagram, wrap them once on the magnetic ring and thread them out from the corresponding cable connector below the casing.

Please use a Phillips screwdriver with a suitable torque of 10Nm.

Please insert the appropriate network cable into the battery communication port and BMS RS485/CAN interface on the PCS according to the battery configuration, and thread the network cable out of the COM cable connector below.

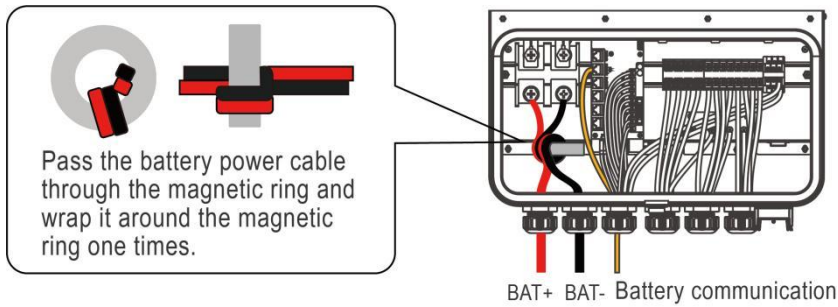

NOTE:

1. Ensure that the polarity of the battery and PCS are correctly connected, otherwise PCS may be damaged.
2. APstorage ELS/ELT series PCS are DC/AC isolated, so the battery ground should not be connected to AC ground. Leave battery ground point floating could ensure the system working safely and stably.

STEP 3 AC Wiring

The LOAD/GEN terminal uses a cross screwdriver with a suitable torque of 1.2Nm; The GRID terminal uses a cross screwdriver with a suitable torque of 2.5Nm. Please thread the cables of LOAD/GEN/GRID separately through the cable connectors marked with LOAD/GEN/GRID below.

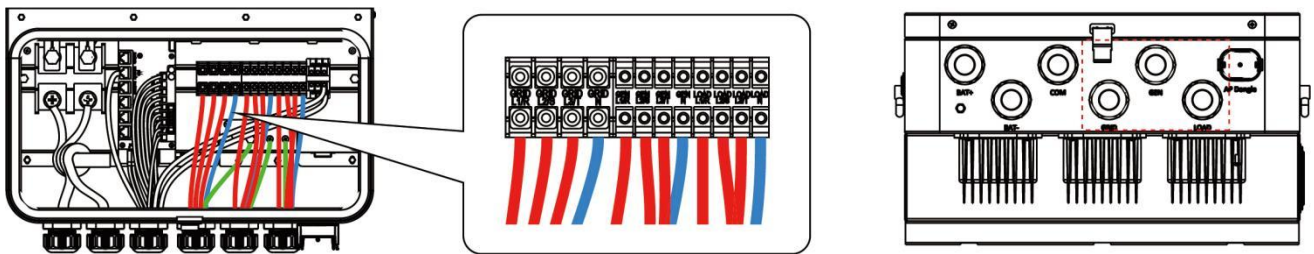

NOTE: Please ensure that the N and L wires are connected accurately

STEP 4 Grounding Wiring

- A: For GRID AC connection
- B: For GEN AC connection
- C: For LOAD AC connection

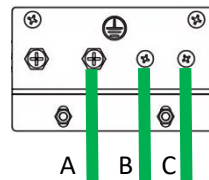

NOTE: A Torque value is 2.5Nm; B/C Torque value is 1.2Nm.

STEP 5 CT Wiring

The CT ring wiring is shown in the following figure, where CT1/2/3 corresponds to grid L1/2/3 and CT7/8/9 corresponds to L1/2/3 of GRID-PV.

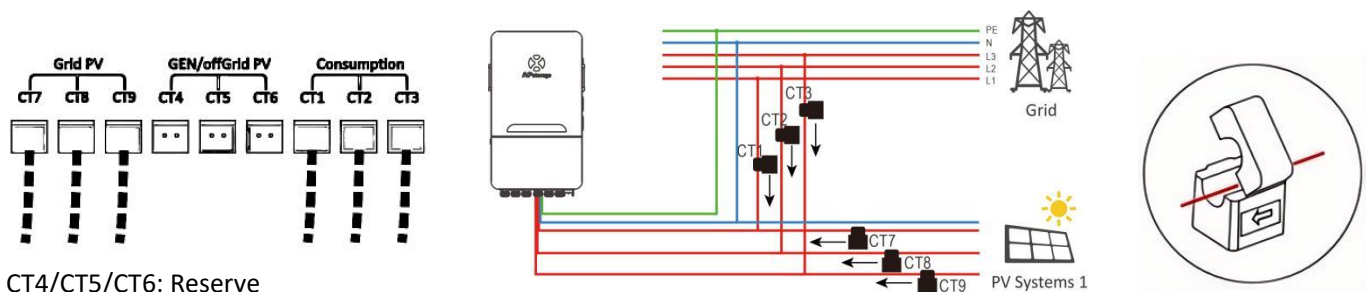

The arrows on the CT ring (as shown in the figure) should all point towards PCS. Please thread the wire of the CT ring through the COM cable connector below.

STEP 6 AP Dongle Installation

AP Dongle is an intelligent communication expansion module used in conjunction with PCS to achieve wireless communication between PCS and the management system through WLAN and Bluetooth.

- ① Pull out the USB interface protective cover;
- ② Insert the AP Dongle into the USB interface, and the buckle will make a sound when tightened;
- ③ After PCS power supply, the operating status can be observed through LED display.



NOTE:

1. When the AP Dongle is powered on normally, the green light remains on. When connected to WIFI, both the green and blue lights will remain on.
2. If Bluetooth is not connected for 1 hour, it will automatically turn off. To reactivate the Bluetooth function, please press the corresponding button or plug and unplug to restart.

STEP 7 Network port wiring

Please use the appropriate network cables for the COM Connection based on your needs. All network cables should be routed out from the COM cable connector at the bottom.

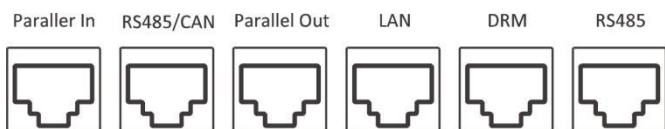

NOTE:

The Parallel In/Parallel Out/DRM feature is temporarily unavailable.

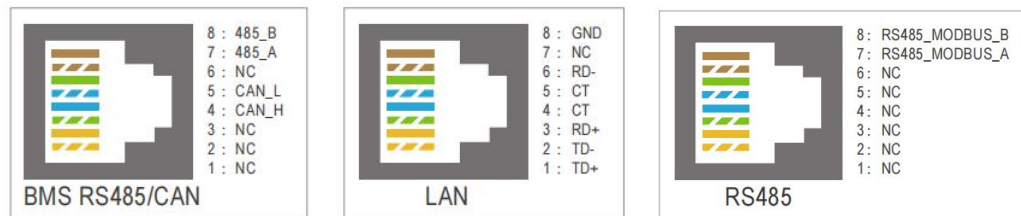

STEP 8 Lower cover installation

After completing all cable connections, please tighten the nuts of all cable connectors.

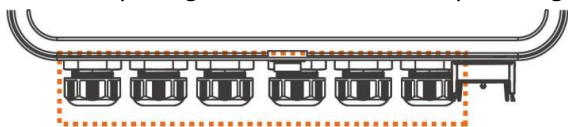

After completing all the above steps, please fasten the lower cover buckle first, and then tighten the screws.

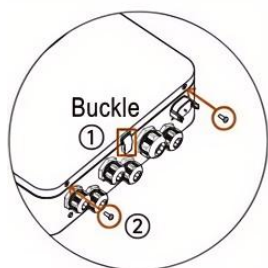

3.6 Wiring System for PCS

This diagram is an example for an application that neutral connects with the PE in a distribution box. For countries such as Australia, New Zealand, South Africa, etc., please follow local wiring regulations!

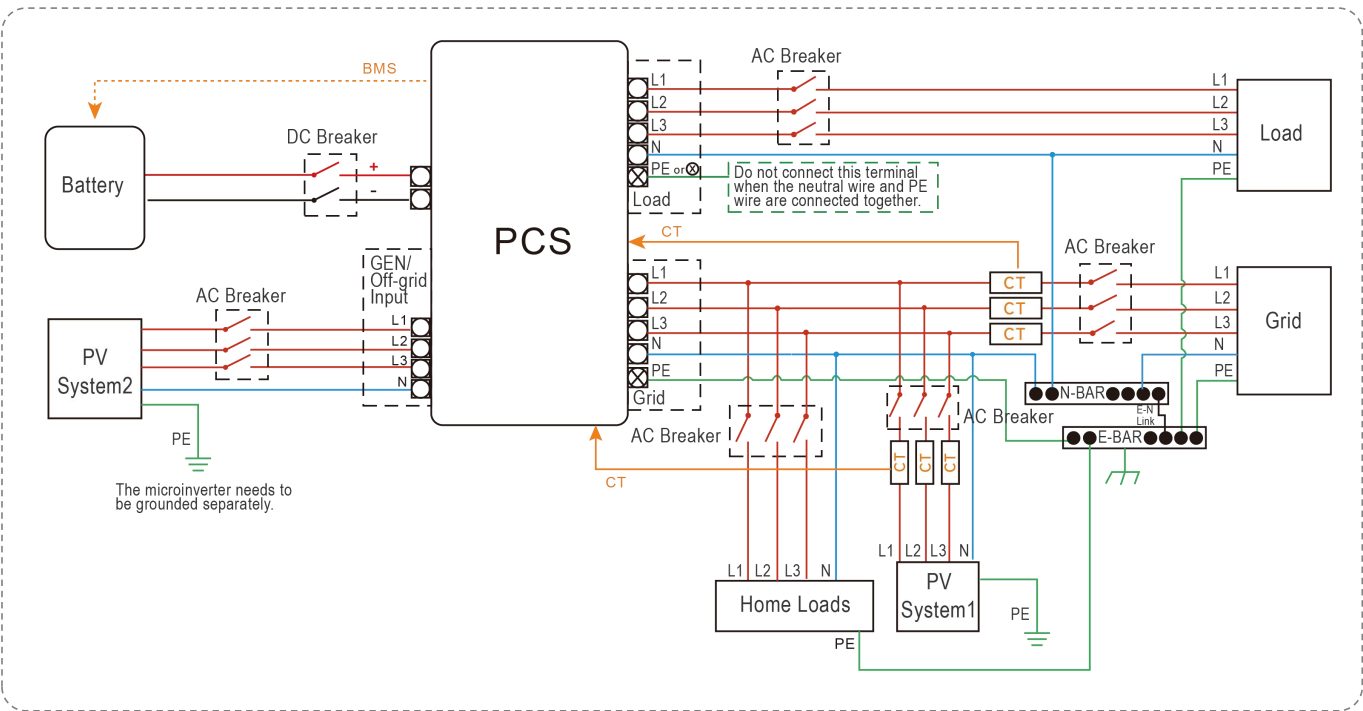

When the inverter is working in backup mode, neutral and PE on the backup side are connected via the internal relay. Also, this internal relay will be open when the inverter is working in grid tied mode.

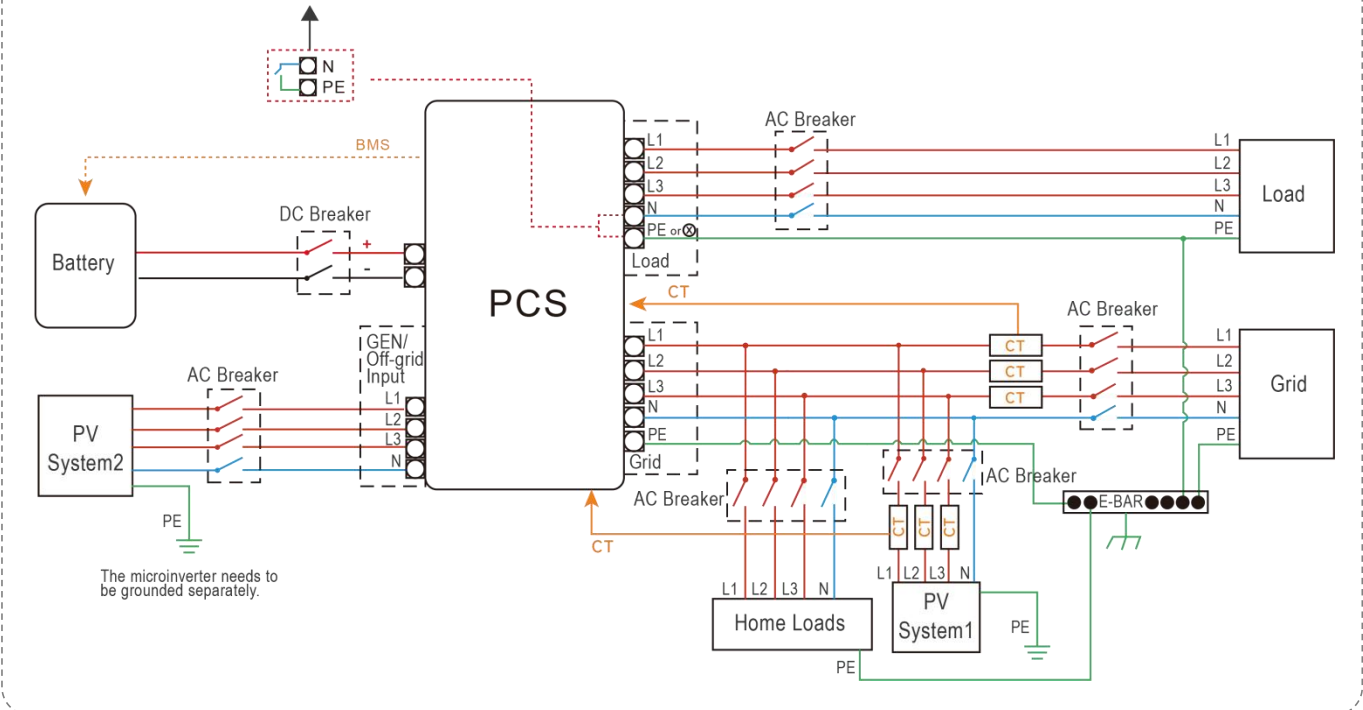

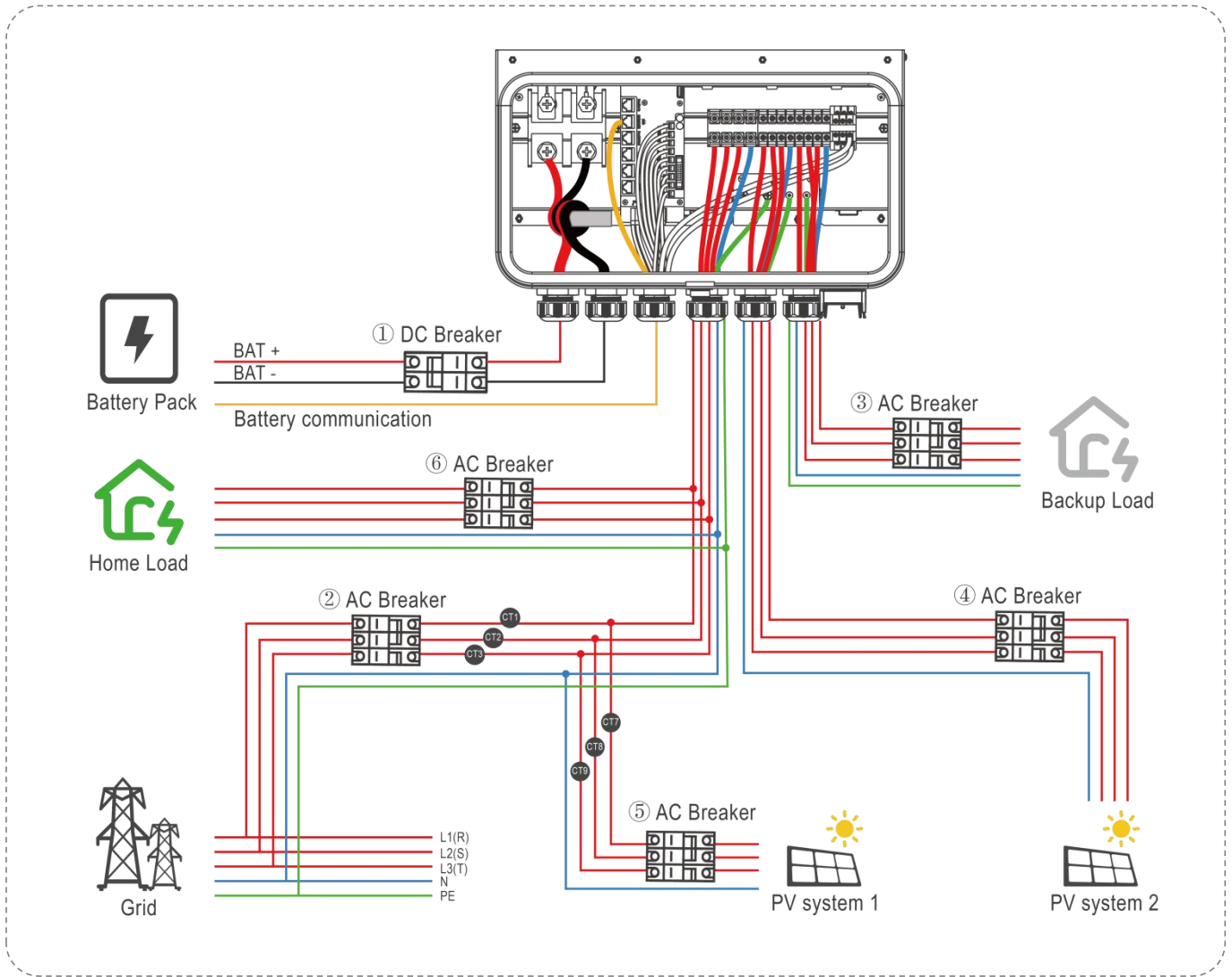

① DC Breaker for battery

- ELT-6: 200A DC breaker
- ELT-8: 250A DC breaker
- ELT-10: 300A DC breaker
- ELT-12: 300A DC breaker

② AC Breaker for Grid

- ELT-6: 32A AC breaker
- ELT-8: 32A AC breaker
- ELT-10: 63A AC breaker
- ELT-12: 63A AC breaker

③ AC Breaker for PV system 2

- ELT-6: 16A AC breaker
- ELT-8: 16A AC breaker
- ELT-10: 32A AC breaker
- ELT-12: 32A AC breaker

④ AC Breaker for Load

- ELT-6: 16A AC breaker
- ELT-8: 16A AC breaker
- ELT-10: 32A AC breaker
- ELT-12: 32A AC breaker

⑤ AC Breaker for PV system 1

Depends on PV system 1

⑥ AC Breaker for home load

Depends on household loads

3.7 Start PCS

3.7.1 Check all Below Steps Before Starting PCS

- ① Make sure the PCS is properly mounted to the wall.
- ② Make sure all the DC wirings and AC wirings are completed.
- ③ Make sure the CT is connected properly.
- ④ Make sure the battery is connected properly.
- ⑤ Make sure all grounded busbar are connected property.
- ⑥ Make sure the PV system is connected properly.
- ⑦ Make sure the loads and critical loads are connected property, and the critical loads rating is within nominal rating range.

3.7.2 Power ON

When the PCS is properly installed and the battery is firmly connected, please proceed according to the following steps:

- ① Turn on the Battery DC breaker;
- ② Turn on the batteries;
- ③ Press the on/off button, wait for 1 minute until the button's green light turns on;
- ④ Based on the connected equipment and usage requirements, turn on Grid AC Breaker, PV AC Breaker and Load AC Breaker.

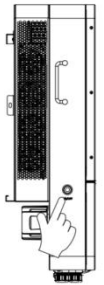

3.7.3 Check the system

Please refer to EMA APP User manual to check the system.

3.7.4 Power Off

Press the on/off button, turn off the Battery DC Breaker, Grid AC Breaker, PV AC Breaker and Load AC Breaker to shut down the system power, then turn off the batteries.

WARNING:

Installation must be performed with care. Before making the final DC connection or closing DC breaker/disconnect, be sure positive(+) must be connect to positive(+) and negative(-) must be connected to negative(-). Reverse polarity connection on battery will damage the inverter.

WARNING:

The installer is responsible for providing overcurrent protection.To reduce the risk of fire, install a circuit breaker or overcurrent device on both positive(+) and negative(-) conductors to protect the system.

4. Off-Grid AC Coupling Installation

4.1 Frequency Shift Power Control

Functional Overview

If the PV inverter is connected to the GEN side of the PCS in the system, the PCS must be able to limit its output power. This limitation is necessary when the battery of the PCS is fully charged and the available power of the photovoltaic system exceeds the power demand of the connected load. In order to prevent the battery from overcharging, the PCS uses the measured the photovoltaic power and the requested charging power from battery to adjust the frequency of the microgrid, and the photovoltaic inverter adjusts the output power by detecting the change of the frequency of the microgrid.

The Frequency shift power control is enabled by default on PCS. At the same time, it is necessary to ensure that the PV System 2 is correctly connected to the Production CTs, the overfrequency load reduction function is enabled in PV system2, and is set according to the APstorage over-frequency load reduction parameter setting table.

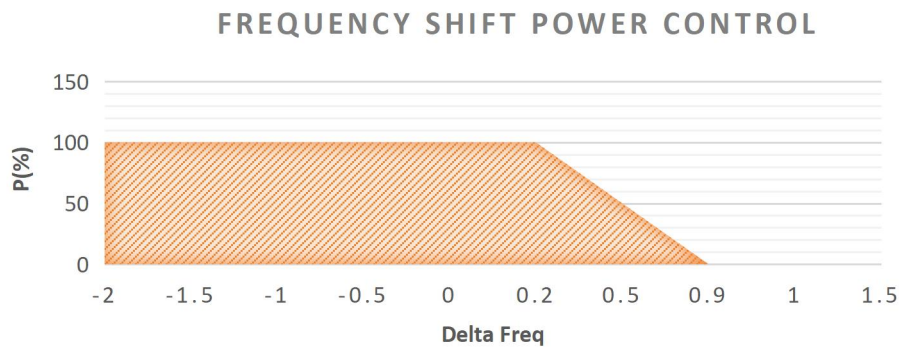

Example PV Inverter Function showing Power vs Delta Frequenc

In the graph above, the horizontal axis is variation of the frequency, 0 is the rated frequency. The vertical axis represents the percentage of the current power to the rated power. The photovoltaic power changes with the microgrid frequency controlled by the PCS.

NOTE:

The frequency change curve shown in above figure is only for display purposes. The specific parameters of the photovoltaic inverter and PCS are set according to the local certification standards and APstorage over-frequency load reduction parameter setting table.

4.2 PV System to APstorage Pairing

1. Determine the maximum single load power rating (kW) to be backed up and select the absolute minimum number of PCS units.
 2. Calculate the required energy storage capacity (kWh) based on the backup load estimate for the user defined time period, capacity and the minimum number of batteries required.
 3. Calculate the maximum power (PV module 2) of the photovoltaic system connected to the PCS in Table 1.
- Note the number is different if the PV inverter has Frequency Curtailment and/or not.
 If the total power of the photovoltaic system is greater than the maximum power, the excess power (PV System 1) is connected to the grid side.

Table 1: The maximum power of the photovoltaic system for storage system backup			
Solar Inverters Used	# of APbattery -51.2V/10.24kWh	Maximum Offgrid Output Power kWac	Maximum Offgrid PV Size kWac
APsystems Inverters QT2/QT2D/DS3/DS3D	1	6.14	7.67
APsystems Inverters QT2/QT2D/DS3/DS3D	2	12	15
Other Inverters	1	6.14	6.14
Other Inverters	2	12	12

Two calculation examples are given below for reference:

- Step 1: Figure out Battery Max Charge Power
- Step 2: Figure out PCS Charge Power
- Step 3: Take the smaller number
- Step 4: Multiply by 1.25 (If using Frequency Power Control)

Table 2: Examples Calculation of Off-grid Solar	
1 ELT-12+1 APbattery-51.2V/10.24kWh 1. Battery Power = 6.14kW 2. PCS Power =12kW 3. Battery Power is smaller than PCS Power 4. Other Off-grid PV power is 6.14kW APsystems Off-grid PV power is 7.67kW	1 ELT-12+2 APbattery-51.2V/10.24kWh 1. Battery Power = 12.28kW 2. PCS Power = 12kW 3. PCS Power is smaller than Battery Power 4. Other Off-grid PV power is 12kW APsystems Off-grid PV power is 15kW

5. User Interface

Professional and certified Installer can commission, monitor and maintain the APStorage solution and performance via the EMA Manager APP. Please search for the APP in APP Store or Google Play, or use mobile browser to scan the QR codes to download the APP. (EMA App is for end-users, EMA Manager is for installers).



Please scan the QR for EMA APP

NOTE: For Connection and monitoring operation mode, please refer to the EMA APP User Manual.

NOTE: If the PCS has not undergone energy storage initialization testing, please refer to the EMA Manager Guide for PCS initialization Process. Please Scan the QR to download and install the EMA Manager app.



Please scan the QR for EMA Manager APP

6. Introduction to working mode

The PCS has two working modes: **AI Mode** and **Standard Mode**.

NOTE: Currently, only some European countries (such as Germany, the Netherlands, Belgium, Spain, the UK, and Sweden) support the dynamic electricity tariffs function, so the AI mode is only displayed in these countries.

6.1 Standard Mode

The conventional mode of APstorage PCS provides diversified options, including Backup power supply mode, Self-consumption mode, advanced and peak shaving mode. Users can flexibly and accurately select the corresponding working mode according to their actual scenarios and specific power consumption needs to meet various daily electricity demands:

- **Backup power supply mode:** Emergency power supply (EPS) mode, the system charge when grid connected and discharge when off grid.
- **Self-Consumption mode:** APstorage charges when solar power is produced more than home requires, and the power is used for household appliances when your home requires more power than your solar system can provide.
- **Advanced mode:** Discharge during peak time, charge during off-peak time.
- **Peak-Shaving mode:** Input peak-shaving power, when the power of load exceeds the set value of peak-shaving power, the excess power is provided by PCS.

6.2 AI Mode

This mode is applicable to users who have signed dynamic electricity tariffs contracts. The system will automatically optimize the battery charging and discharging strategy based on the hourly electricity tariffs, using intelligent algorithms to make the best decisions according to each family's priorities and needs. The goals are to save excess photovoltaic power, use off-peak periods to charge the battery, and discharge to the grid during peak periods to maximize revenue.

7. Technical Data

Model	ELT-6	ELT-8	ELT-10	ELT-12
General Specifications				
Dimensions W/H/D	818mm × 474mm × 275mm			
Weight	45.75kg			
Maximum Efficiency	96.5%			
Operating Ambient Temperature Range	-25°C-65°C, >45°C derating			
Storage Temperature Range	-40°C-85°C			
Environment category	Outdoor			
Ingress Protection	IP65			
Pollution Degree Classification	PD2			
Noise	< 40dB ⁽¹⁾			
Relative Humidity	4%-100%			
Protective Class	Class I			
Over Voltage Category	III (MAINS), II (Battery)			
Cooling	Smart cooling			
Permissible Altitude (m)	≤2000m			
Communication Ports	WIFI/Bluetooth/RS485/CAN			
Wi-Fi Frequency Range	2412MHz - 2472MHz			
Wi-Fi Maximum Power (EIRP)	17.67 dBm			
Bluetooth Frequency Range	2402MHz - 2480MHz			
Bluetooth Maximum Power (EIRP)	8.57 dBm			
Grid Regulation	VDE-AR-N 4105, EN 50549-1, EN 50549-10, NF EN50549-1, NF EN50549-10, PN EN50549-1			
Safety	EN IEC 62477-1			
EMC	EN IEC 61000-6-1, EN IEC 61000-6-2, EN IEC 61000-6-3, EN IEC 61000-6-4, EN 55011, EN 62920			
Warranty	10 years			
Battery Input /Output Data				
DC Battery Input Voltage	40-60VDC			
Charging Strategy for Li-Ion Battery	Self-adaption to BMS			
Charging Curve	3 Stages / Equalization			
Max Continuous Charge Current	135A	180A	225A	240A
Max Continuous Discharge Current	135A	180A	225A	240A
AC Input/Output Data (On-grid)				
Max. Continuous Output Power	6000VA	8000VA	10000VA	12000VA
Max. Continuous Output Current	8.7A	11.6A	14.5A	17.4A
Max. Continuous Current From Utility	17.4A	23.2A	29A	34.8A
Nominal Output Voltage	400V, 3L/N/PE			
EPS Switch Time	10ms			
Nominal Output Frequency/Range	50Hz/47.5Hz-51.5Hz			
Output Power Factor	>0.99 (Adjustable from 0.8 leading to 0.8 lagging)			
THD	<3%			
Grid Connection	Three-phase			
AC Output Data (Backup)				
Max. Output Apparent Power	6000VA	8000VA	10000VA	12000VA
Peak Output Apparent Power	9000VA(10s)	12000VA(10s)	15000VA(10s)	18000VA(10s)
Max. Output Current	8.7A	11.6A	14.5A	17.4A
Nominal Output Voltage	400V, 3L/N/PE			
Nominal Output Frequency	50Hz			
AC Input Data(Off-Grid Input/Gen)				
Max. Input Apparent Power	6000VA	8000VA	10000VA	12000VA
Peak Input Apparent Power	9000VA(10s)	12000VA(10s)	15000VA(10s)	18000VA(10s)
Max.Input Current	8.7A	11.6A	14.5A	17.4A
Nominal Input Voltage	400V, 3L/N/PE			
Nominal Input Frequency	50Hz			

(1) To keep the PCS noise below 40dB, the ambient temperature must be below 40°C. This data was tested at a distance of 1m under typical conditions in the APstorage laboratory.

© All Rights Reserved

Specifications subject to change without notice please ensure you are using the most recent update found at web : emea.APsystems.com

EU DECLARATION OF CONFORMITY

(No. 20240522)

We, ALTENERGY POWER SYSTEM INC.

Of

Building 2, No. 522, Yatai Road, Nanhu District, Jiaxing City, Zhejiang 314050, China

declare under our sole responsibility that the product

Product Description: Power Conversion System

Model No.: ELT-12, ELT-10, ELT-8, ELT-6

to which this declaration relates, is in conformity with the following standards and/or other normative documents.

Safety	EN 62477-1:2012; EN 62477-1:2012/A11:2014 EN 62477-1:2012/A1:2017; EN 62477-1:2012/A12:2021
Health	EN IEC 62311:2020; EN 50665:2017
EMC	EN 55011:2016/A2:2021; EN IEC 61000-6-1:2019; EN IEC 61000-6-2:2019; EN IEC 61000-6-3:2021; EN IEC 61000-6-4:2019; EN IEC 61000-3-2:2019+A1:2021; EN 61000-3-3:2013/A2:2021; EN IEC 61000-3-11:2019; EN 61000-3-12:2011; EN 301 489-1 V2.2.3(2019-11); EN 301 489-17 V3.2.4(2020-09)
Radio	EN 300 328 V2.2.2(2019-07)

We hereby declare that the above named product is in conformity with to all the essential requirements of Radio Equipment Directive 2014/53/EU (RED).



Title: Director

Address: Jiaxing, China

Date: 2024/05/24

APsystems EMEA

Karspeldreef 8, 1101 CJ, Amsterdam, The Netherlands

Email: info.emea@APsystems.com

Web: emea.APsystems.com

APsystems France

22 Avenue Lionel Terray 69330 Jonage, France

Mail: info.emea@APsystems.com

Web: emea.APsystems.com